

## Bedford Mini Tyer™ Pro



Scan this code for  
our interactive  
webpage





## Table of Contents

Safety .....	4
1.0 Specifications .....	5
1.1 Terminology .....	5
1.2 Machine Overview .....	6
2.0 Install & Setup .....	11
2.1 Manually Cycling the Machine .....	11
2.2 Machine Power .....	11
2.3 Threading Tie Ribbon .....	12
3.0 Operation .....	15
3.1 General Operation .....	15
3.2 End of Day/Shift .....	15
4.0 Maintenance .....	16
4.1 Setting the Tie Stop .....	16
4.2 Lubrication Points .....	17
4.3 Clearing a Jam .....	18
4.4 Setting the Drive Gear Height .....	19
5.0 Troubleshooting .....	20
6.0 Parts .....	22
6.1 Springs .....	23
6.2 Microswitches .....	25
6.3 Feed Roller .....	27
6.4 Pinion Block Assembly and Linkages .....	28
6.5 Feed Drum .....	31
6.7 Tie Guide, Gear, and Cam .....	32
6.8 Base Plate and Motor .....	33
6.9 Anti-Backup Assembly .....	34
6.10 Payout .....	35
7.0 Drawings and Parts Lists .....	36
8.0 Wiring Diagram .....	61
Manufacturer's Literature – Oriental Motor .....	63
Manufacturer's Literature – Siemens PLC .....	67
Manufacturer's Literature – Anser U2 Printer .....	68



***Confidentiality Notice: This document is confidential and contains proprietary information and intellectual property related to the product specifications of Bedford Industries, Inc. Neither this document nor any of the information contained herein may be reproduced or disclosed under any circumstances without the express written permission of Bedford Industries, Inc.***



## Safety

**Read this section before using the equipment. This section contains recommendations and practices applicable to the safe installation, operation, and maintenance of the product described in this document. Additional safety information, in the form of task-specific safety alert messages, appears as appropriate throughout this document.**

**Be sure the following safety instructions are read, understood, and become a part of daily practice when operating or maintaining the closure equipment.**

1. Do not attempt to operate the equipment until you understand its function.
2. Keep all foreign material away from the drive system.
3. Keep fingers and clothes out of the gears and twister hook area.
4. Disconnect the power cord before making any equipment adjustments or maintenance. All moving parts must be completely stopped before working on the machine.
5. After any adjustment, cycle the equipment by hand to ensure proper adjustment has been made. Immediately cycling under power may damage the unit and/or product.

### **Responsibilities of the Equipment Owner**

Equipment owners are responsible for managing safety information, ensuring that all instructions and regulatory requirements for use of the equipment are met, and for qualifying all potential users.

## 1.0 Specifications

### 1.1 Terminology

- A. **Anti-Backup Assembly** – Assembly at the rear of the base plate where tie enters the machine from the payout.
- B. **Base Plate** – Plate attached to the frame that contains all the mechanical parts of the machine.
- C. **Bevel Drive Gear** – Unique geometry gear mounted on the motor shaft that turns the twister hook.
- D. **Cam** – Special geometry flat plate fastened to the top of the bevel drive gear used to actuate the pack arm and tell the motor when to stop.
- E. **Cutter Knife/Anvil** – Rotating shear knife that cuts tie material. Attached to the rotating pinion shaft assembly.
- F. **Feed Drum** – Knurled drum attached to the bevel drive gear that feeds tie.
- G. **Front of machine** – Refers to side with the throat opening for product to enter.
- H. **Left side of machine** – Refers to side with the threaded spool lock. This side is used to load/unload spools of material on the payout.
- I. **Pack Arm** – Packing lever near the front of the machine that pushes the tie material around the bundle after it is fed into the machine and holds it in place while the twister hook grabs the end to tie the material around the bundle.
- J. **Payout** – Assembly at the rear of the machine where tie material is loaded/unloaded.
- K. **Pinion Block Assembly** – Block fastened to the base plate that contains the twister hook, knife, and rotating pinion gear. Tie is threaded through this assembly and guided to the knife and twister hook.
- L. **Pinion Gear** – Meshes with the drive gear to turn the twister hook.
- M. **Pivot Arm and Feed Roller** – Pivoting lever that clamps tie against feed drum to feed material.
- N. **Right side of machine** – Refers to side that contains the plug, ON/OFF switch, and PLC/counter.
- O. **Throat** – Opening at the front of the machine where product enters to be bundled.
- P. **Tie Guide** – Block fastened to the base plate which tie flows through before entering the pinion block assembly.
- Q. **Trigger** – Actuating lever at the front of the machine that starts the machine cycle. It is located at the throat of the machine.
- R. **Twister Hook** – Rotating section of machine through which tie is wrapped around product bundle and twisted to cinch product together.

**1.2 Machine Overview**



*Figure 1.2.1 View of Bedford Mini Tyer™ Pro*

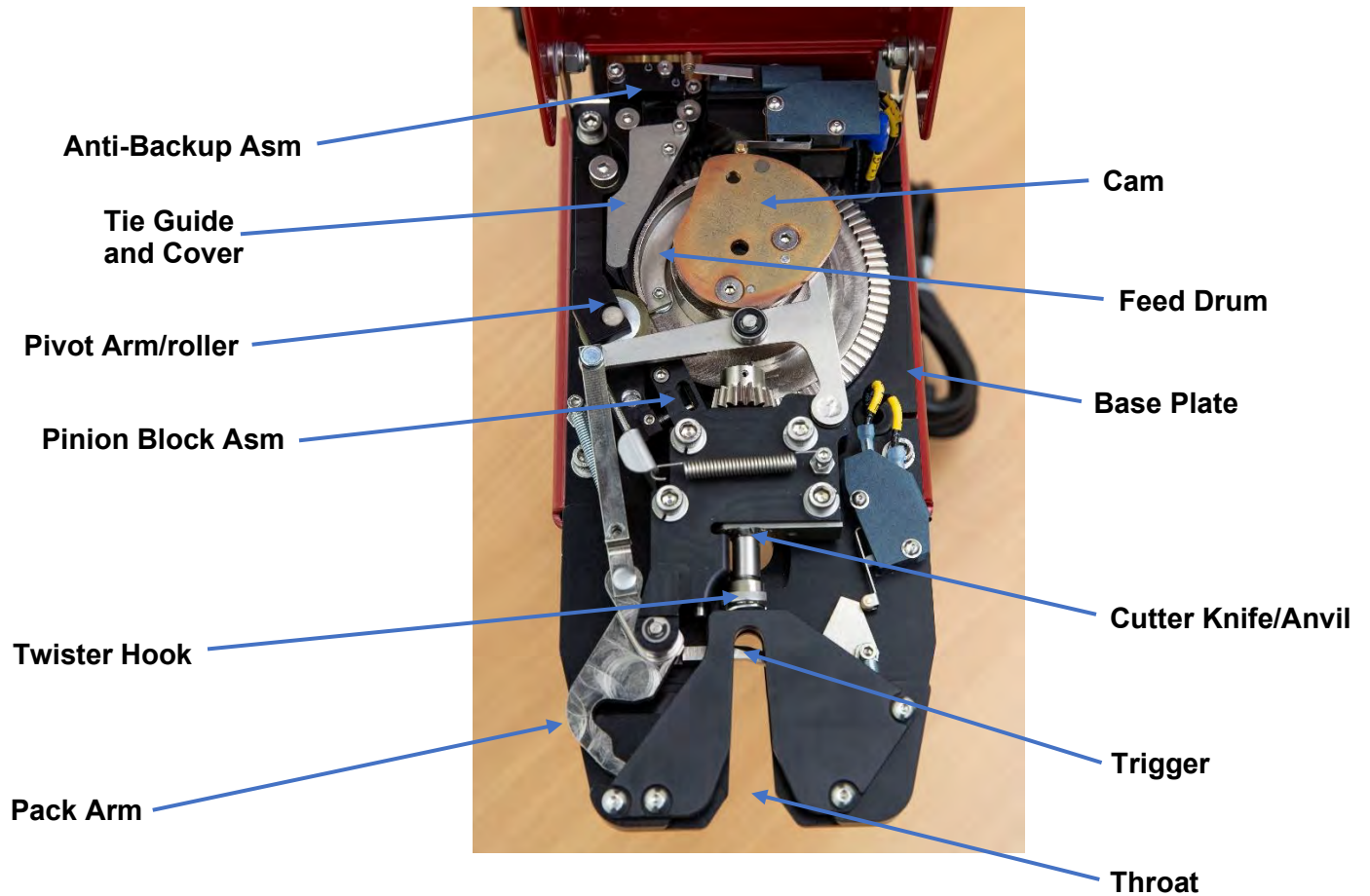

*Figure 1.2.2 View of Bedford Mini Tyer™ Pro*

## 1. Throat

(Reference Figure 1.2.1.1)

1.1 This is the opening at the front of the machine where the product enters to be bundled.

**CAUTION: Do not insert fingers or foreign items into the throat of the machine while the machine is operating.**



Figure 1.2.1.1 Throat Opening

## 2. Machine Trigger

(Reference Figure 1.2.2.1)

2.1 Actuating lever located in the throat of the machine. When pressed, it will trigger a microswitch to start the motor and cycle the machine.

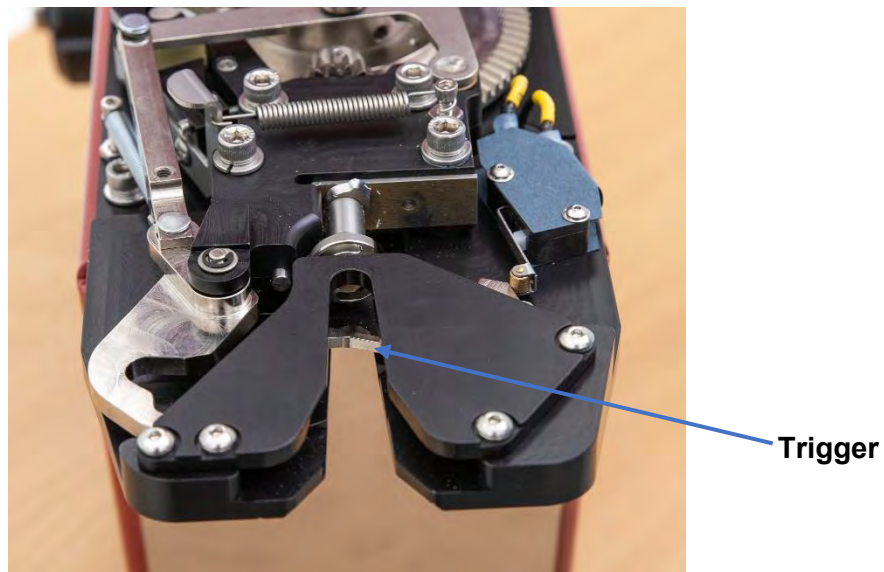

Figure 1.2.2.1 Trigger

### 3. Machine Switches

(Reference Figure 1.2.3.1, 1.2.3.2, & Figure 1.2.3.3)

- 3.1 Lid Switch – Mounted on a block attached to the base plate near the rear of the machine under the lid. This switch is activated by the lid to prevent machine cycling when the lid is open. This is a safety switch to prevent injury if the machine has power.

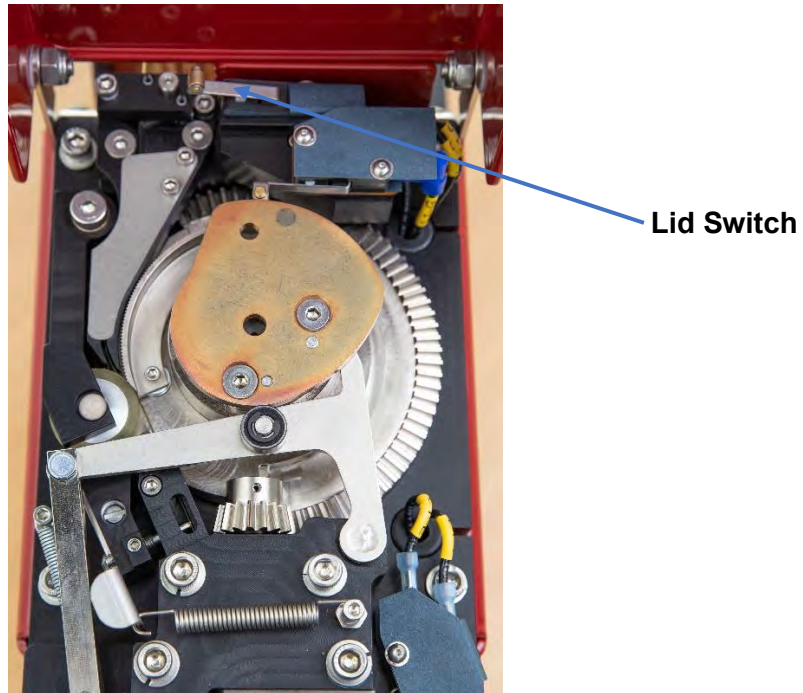

Figure 1.2.3.1 Lid Safety Switch

- 3.2 Trigger Switch – Located on the right of the base plate under the lid. This switch is activated by the trigger to start the cycling process.

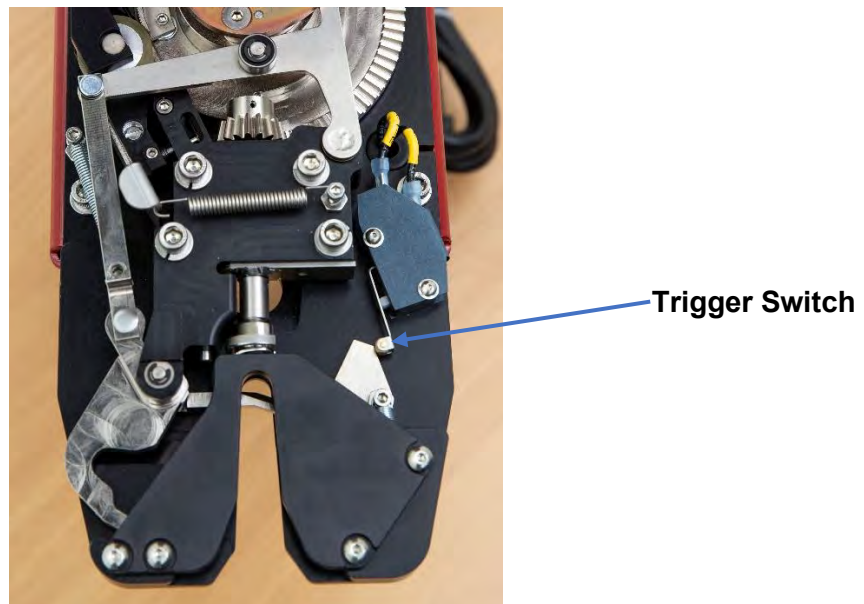
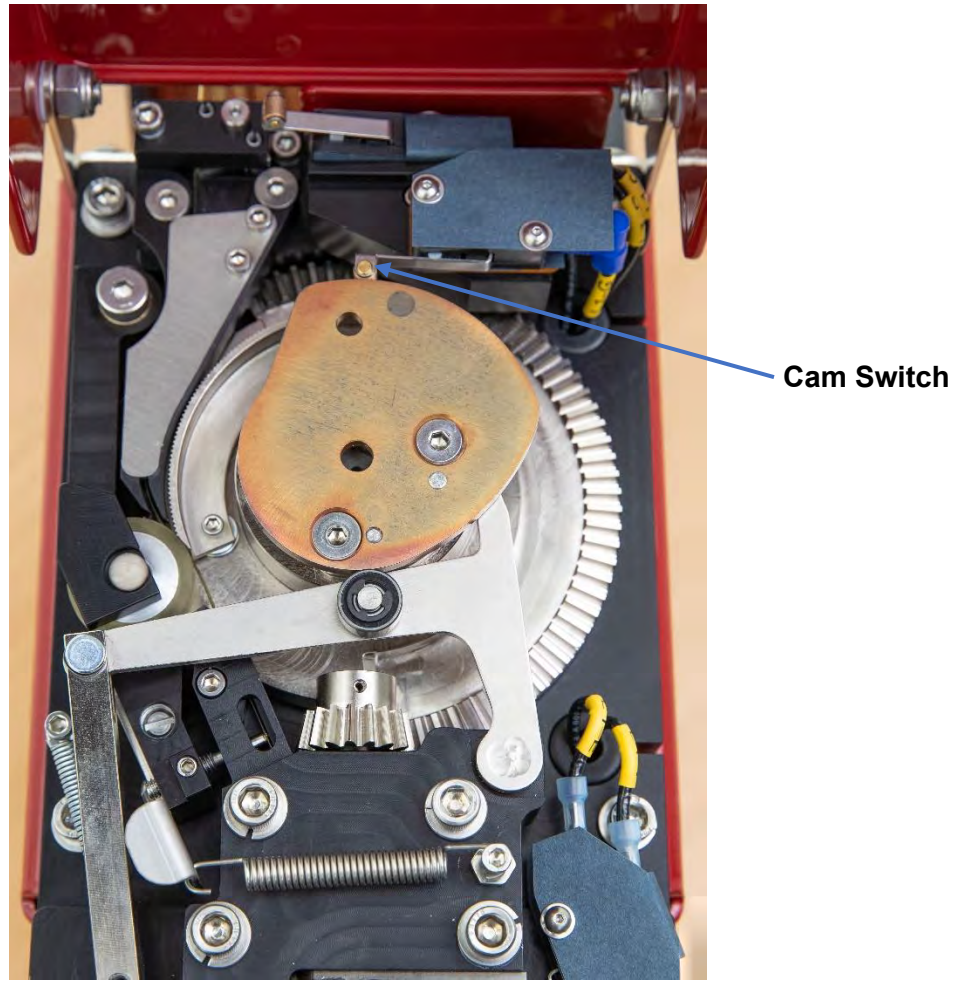

Figure 1.2.3.2 Trigger Switch



- 3.3 Cam Switch – Mounted on a block attached to the base plate near the rear of the machine under the lid. This switch is activated by the cam attached to the bevel drive gear. This switch helps control the mechanical timing of the machine and signals the motor when to shut off at the end of a cycle.



*Figure 1.2.3.3 Cam Switch*

## 4. Other Machine Control Points

(Reference Figure 1.2.4.1 & Figure 1.2.4.2)

- 4.1 Siemens PLC – Located on the right side of machine. This controller is responsible for the control of the machine as well as the cycle counter and other features. To reset the cycle counter, press the up arrow and ESC simultaneously. Refer to 8.0 Wiring Diagram for a depiction of the buttons. There is an ethernet cable also provided at the rear of the machine to allow networking and data logging within the controller.
- 4.2 Counter (if not equipped with PLC) – Located on the right side of machine. This is a resettable counter that is based on a complete cycle of the machine.
- 4.3 Power ON/OFF Switch – Located on the right side of the machine.

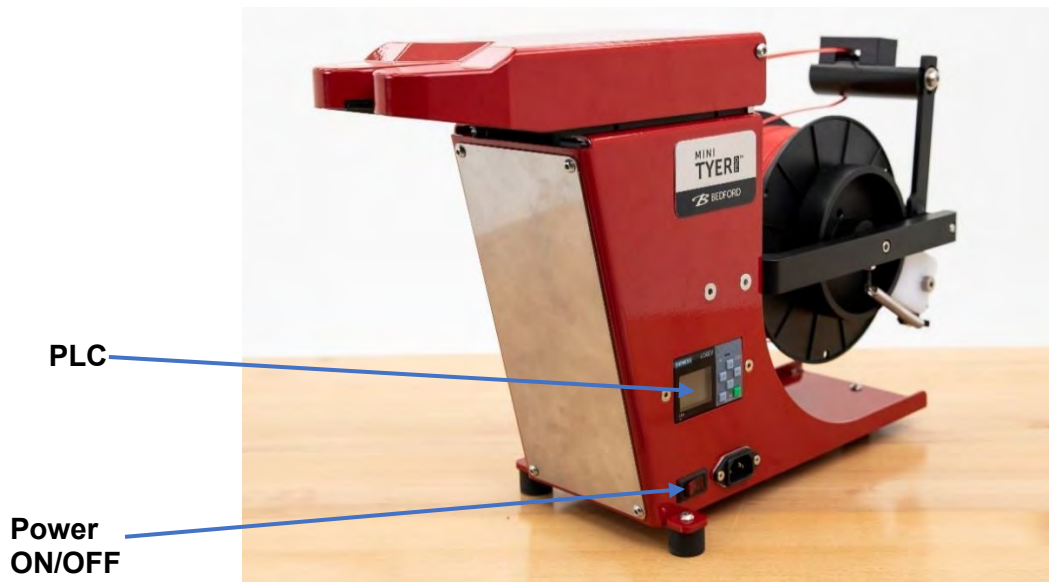

Figure 1.2.4.1 PLC/Counter and ON/OFF Switch

- 4.4 Solid State Timer (only equipped on non-PLC models) – Located inside the machine and fastened to the bottom of the frame. This timer starts and stops the motor when the trigger is activated and a tying cycle begins. Machines equipped with a PLC will control this action through the PLC programming and do not require this component.



Figure 1.2.4.2 Counter and Solid State Timer



## 2.0 Install & Setup

### 2.1 Manually Cycling the Machine

The machine can be manually cycled by hand to diagnose machine issues.

1. Ensure the machine is off and disconnected from power before manually cycling the machine. No material should be loaded on the machine when cycling manually.
2. Open the lid to expose the machine mechanics.
3. Turn the bevel drive gear counterclockwise to simulate a cycle.
  - a. The feed roller will roll against the feed drum located on the gear.
  - b. The cam will push the linkage assembly and allow the pack arm to actuate around the twister hook. *NOTE: This part of the cycle will require some force to overcome the pressure from the pack arm spring.*
  - c. Next, the pinion gear will mesh with the bevel drive gear and turn the cutter knife and twister hook shaft.
  - d. Finally, as the gears finish turning, the pack arm will move back to its starting position which completes the cycle.
4. Ensure the machine is back at the starting position before operating the machine under power.

### 2.2 Machine Power

1. Plug power cord connector into 120 VAC (or 240 VAC if equipped) wall outlet.
2. Toggle power switch to ON position. The red light should glow, indicating power to the system.
3. The machine is now in an operation state. It can be cycled without tie material by activating the trigger in the throat opening. *Note: The lid must be closed to operate as the lid safety switch must be closed.*

***CAUTION: Keep body parts clear of throat opening and twister hook when operating the machine.***

## 2.3 Threading Tie Ribbon

(Reference Figure 2.3.1, Figure 2.3.2, Figure 2.3.3, & Figure 2.3.4)

Locate the payout at the rear of the machine. The spool (1) mounts on the left side of the machine. Refer to the String Up diagram under the lid for directions on threading tie through the machine.

To load a spool of material:

1. Place the spool on the threaded spindle (3). Ensure the tie is coming off the top of the spool towards the payout dancer arm (Figure 2.3.1).
2. Tighten the spool lock (2) counterclockwise on threads to hold the spool in place.

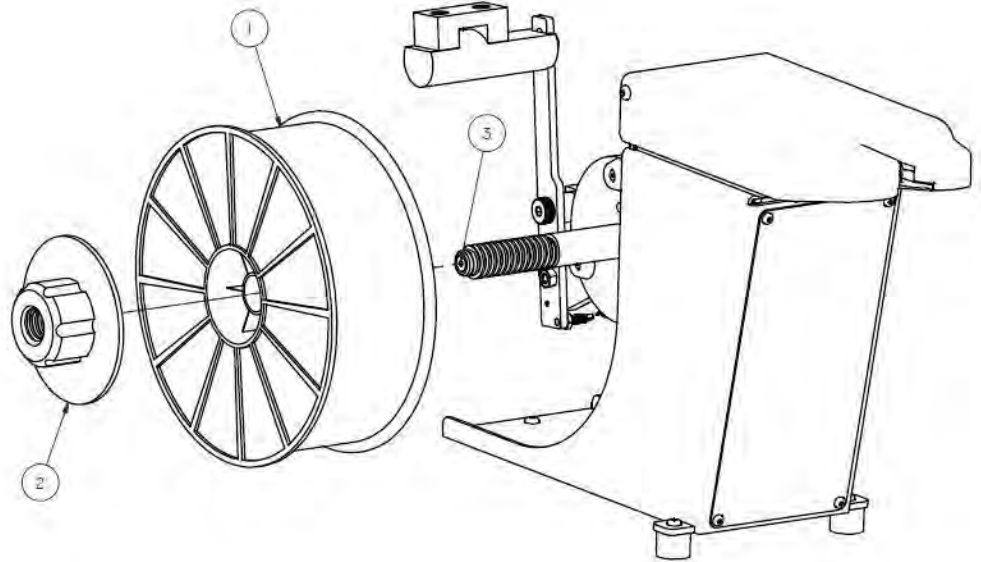

Figure 2.3.1 Loading/Unloading a Spool

**NOTE:** The payout spindle (3) and spool lock (2) have left-hand threads to prevent the spool lock (2) from coming loose during operation.

Tie material feeds off the top of the spool, under the dancer arm (1), through the dancer arm guide, and into the machine.

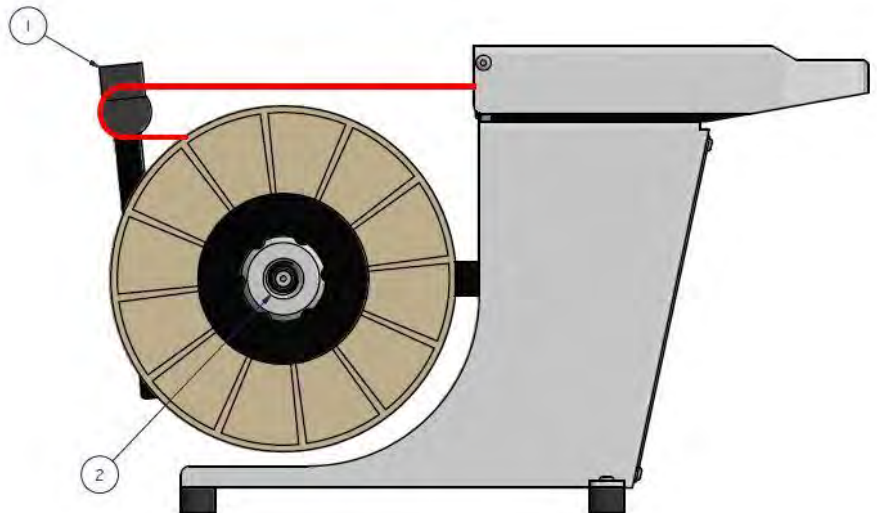

Figure 2.3.2 String Up Diagram Through Machine

**IMPORTANT:** Tie material has a flat side and a wire side. The wire side must be facing towards the left side of the machine.



Wire side of material must be facing this side

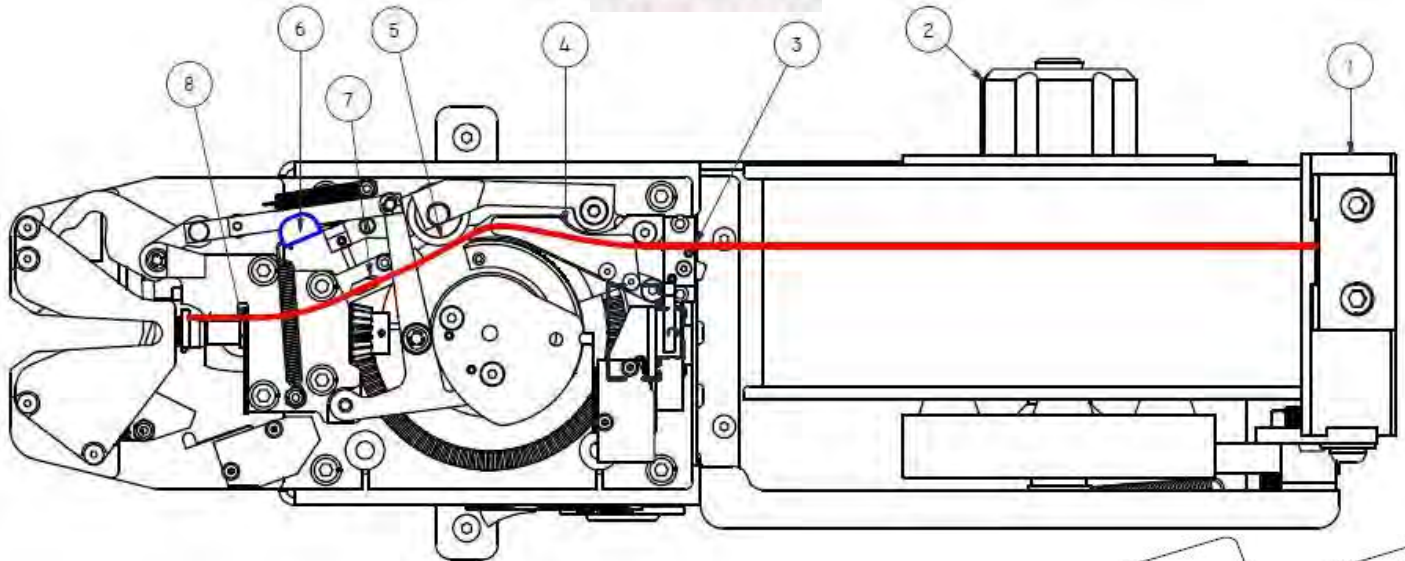

Figure 2.3.3 String Up Diagram Outline

**Bracket -  
 Pull out against the  
 spring in direction shown**

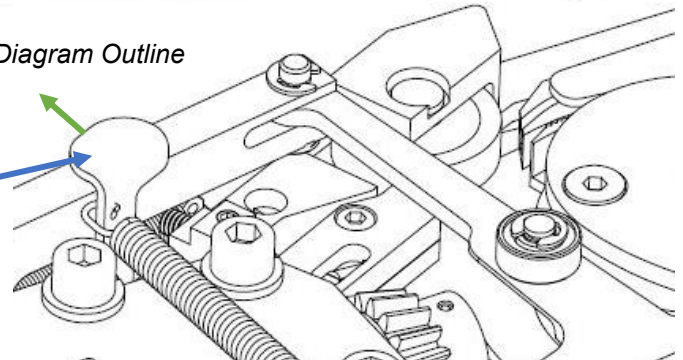

Figure 2.3.4 Pivot Arm Bracket

**Ensure starting position of the machine is correct and matches the figure.**

**Tie material must be straight and undamaged before stringing up.**

1. Cut off or straighten any bent or damaged tie before stringing up for best results.
2. Push tie material into the anti-backup assembly (3) at the rear of the machine (wire side out).
3. Feed the tie from the rear of the machine in small increments to ensure no kinks are created.
4. Tie will then feed through the tie guide (4) before reaching the roller.
5. Pull out the bracket (6), shown in blue, as far as it goes towards the side of the machine and hold it while feeding tie. **Ensure it is all the way out so tie will enter the opening of the pinion block (7).**
6. Tie will move past the roller and into the groove opening (7). If tie does not align properly, additional support such as a screwdriver or needle-nose pliers may be needed to guide the tie into the block.
7. Continue feeding tie until it exits the pinion block groove just past the knife (8).
8. Release the pivot arm (5) using the bracket (6).
9. Close the lid and the machine is ready for operation.

## Unthreading Tie Ribbon

To unthread tie material:

1. Cut the tie material between the spool and anti-backup assembly at the rear of the machine. Refer to *Figure 2.3.4*. If the spool is empty and the tie material is freely detached from the spool, proceed with the following.
2. Open the lid and pull the tie material out by grabbing it at the opening near the feed roller and feed drum. This is near item 5 in *Figure 2.3.3*. A needle-nose pliers might be needed.
3. Pull the material out of the pinion block assembly as well as the tie guide. Ensure no pieces of tie or debris are in the tie threading path before threading new tie material.

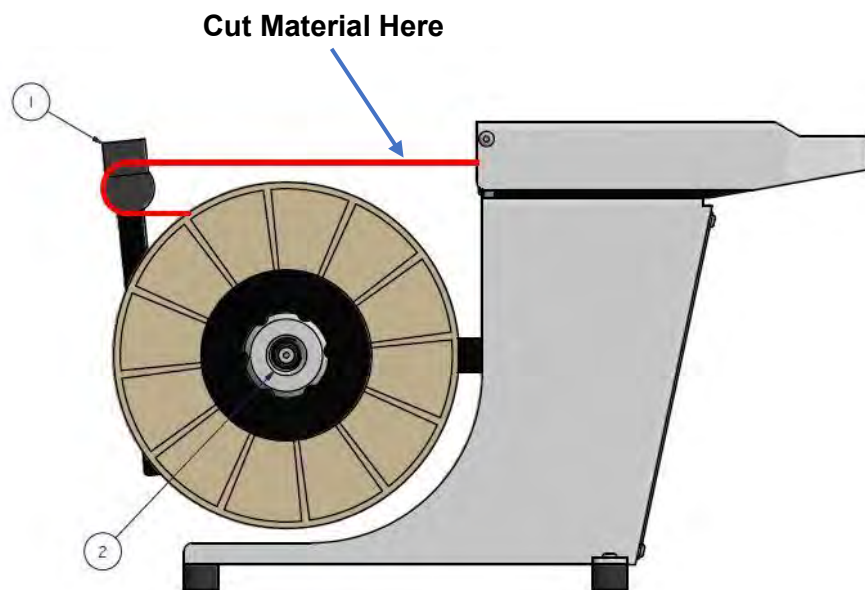

*Figure 2.3.5 Material Path from Spool to Machine*

NOTE: The tie material can also be unthreaded by opening the anti-backup arm at the rear of the machine as well as ensuring the pivot arm is not pinching the material at the tie stop or the feed roller/feed drum and pulling the material out of the rear of the machine towards the spool. Cutting the tie between the payout spool and machine is not necessary for this.



## 3.0 Operation

### 3.1 General Operation

1. Ensure the machine is properly strung up and turned on. Note: The lid must be closed during operation.

*NOTE: The bundle size diameter must be smaller than 0.34 inches for the 3/8 model and 0.56 inches for the 5/8 model. Too large of a bundle can cause the machine to jam or stall.*

2. Hold the bundle vertical and move it to the throat opening at the front of the machine.
3. Push and hold the bundle into the throat all the way so the bundle is up tight to the throat plate and triggers the machine.

*CAUTION: Keep fingers and body parts out of throat opening to prevent injury.*

4. The machine will cycle and tie material around the bundle.
5. Once the cycle is complete, firmly pull the bundle out of the machine.

NOTE: If the tie should jam in the machine, turn the power off, open the lid and find the jammed material. This could be located near the twister hook or the feed roller and feed drum. The tie material may need to be cut between the payout and anti-backup assembly. Pull the tie material out causing the jam and clean any debris present. Re-string up the machine and continue operation. Refer to 4.3 Clearing a Jam

### 3.2 End of Day/Shift

Before leaving the machine at the end of the work shift, the operator must correctly stop the machine as follows:

1. Turn off the machine using the power toggle located on the right side of the machine.
2. Disconnect the machine power plug from the outlet receptacle.

## 4.0 Maintenance

**CAUTION:** Power should be disconnected before performing any maintenance.

Recommendation: Bedford Industries recommends using an anti-seizing, thread-locking compound when installing fasteners. Listed below is the compound used by Bedford during the assembly process:

CRC Food Grade Anti-Seize & Lubricating Compound. Meets NSF requirements with an H1 grade.

**NOTE:** If the customer has additional facility food safety plan or local law requirements, they will need to confirm compound used meets those requirements.

### 4.1 Setting the Tie Stop

(Reference Figure 2.2.1 & Figure 2.2.2)

1. The tie stop is located on the pivot arm assembly. There is a set screw located above the tie stop to lock the stop in place and prevent it from moving during operation. The tie stop prevents the tie material from moving when the machine is not feeding it.

**Note:** The tie stop will be set during initial assembly and should only need adjustment if parts are changed.

- 1.1. To adjust the tie stop, loosen the set screw.
- 1.2. Turn the tie stop either in or out using the same size wrench.

This should be set so that it holds the tie when the roller and feed drum are not in contact but not too much that it does not release the tie when the feed drum pushes the roller/pivot arm out and feeds tie.

This will be visible if the tie starts to bend or kink between the roller/feed drum and pinion block assembly because the tie stop is preventing it from moving forward. If so, loosen the tie stop so it releases sooner. Reference Figure 2.2.1 and Figure 2.2.2 below.

- 1.3. Tighten the set screw so the tie stop cannot move.

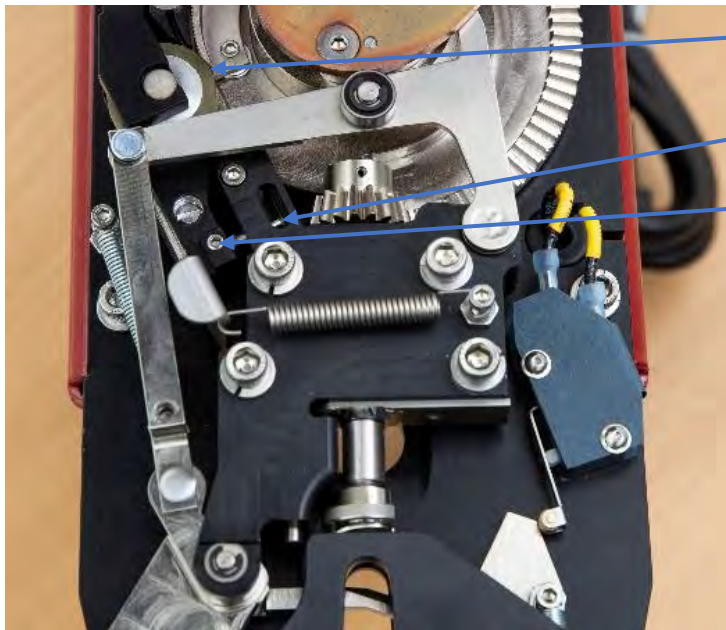

Figure 2.2.1 Tie Stop and Set Screw Photo

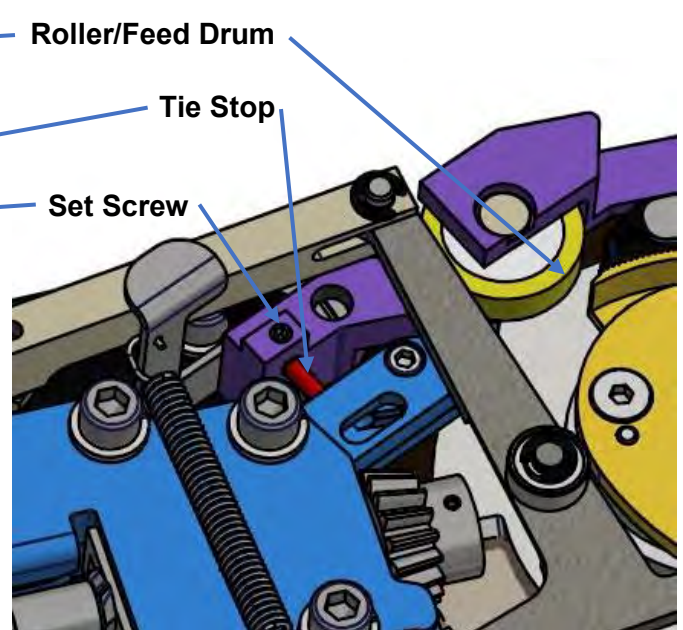

Figure 2.2.2 Tie Stop and Set Screw Drawing



## 4.2 Lubrication Points

(Reference Figure 4.2.1)

The following are recommended points of lubrication and frequency for the Bedford Mini Tyer Pro:

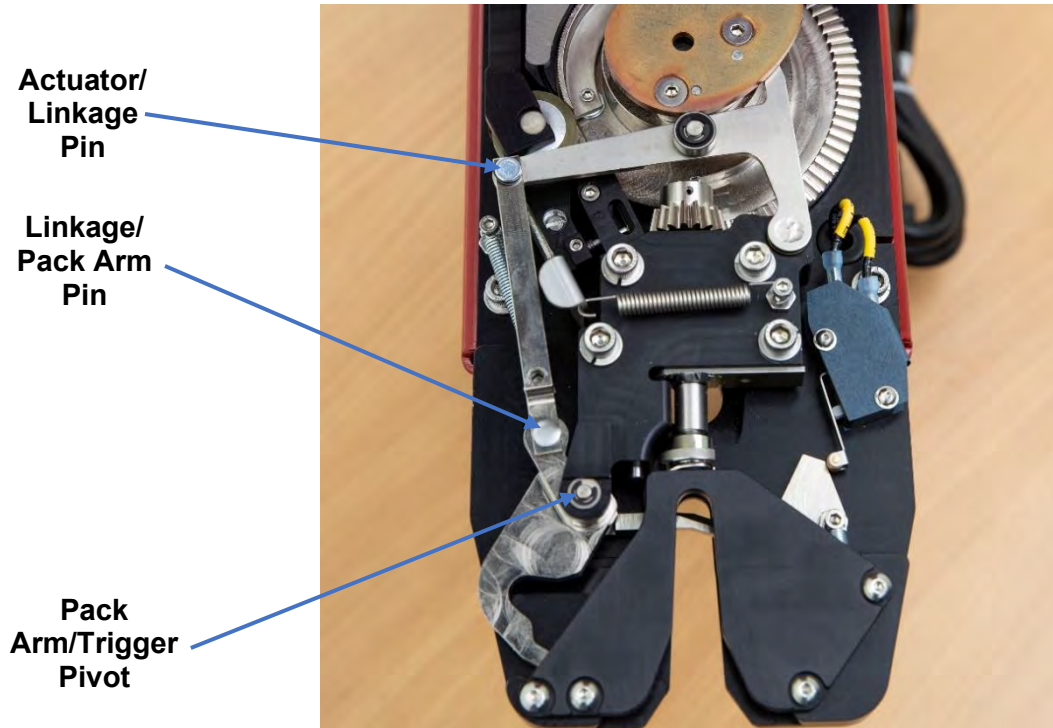

Figure 4.2.1 Lubrication Points

1. Actuator/Linkage Pin: pin location between the actuator weldment and linkage.
2. Linkage/Pack Arm Pin: pin location between the linkage and pack arm.
3. Pack Arm/Trigger Pivot: pivot location of the trigger and pack arm.

Location Point	Cycles
Actuator/Linkage Pin	150,000
Linkage/Pack Arm Pin	150,000
Pack Arm/Trigger Pivot	150,000

Use a lightweight food-grade mineral oil (NSF registered, H1 grade) or similar. Bedford Industries uses UltraSource Food-Grade White Mineral Oil.

These lubrication points do not require much lubricant. A very small drop is sufficient. Too much will cause the lubricant to splatter inside the machine and on the tie material.

Do not lubricate the gears. They are designed to run dry and lubricating them will cause a build-up of debris and potentially damage parts. The other pivoting locations also do not require lubrication as they contain oil-impregnated bushings or bearings.

*NOTE: If customer has additional facility food safety plan or local law requirements, they will need to confirm oil used meets those requirements.*

### 4.3 Clearing a Jam

(Reference Figure 4.3.1)

The tie material may jam in the machine. There are generally two locations this will happen: near the twister hook and knife or at the feed roller/feed drum/gear area. Reasons for tie jamming could be due to the following:

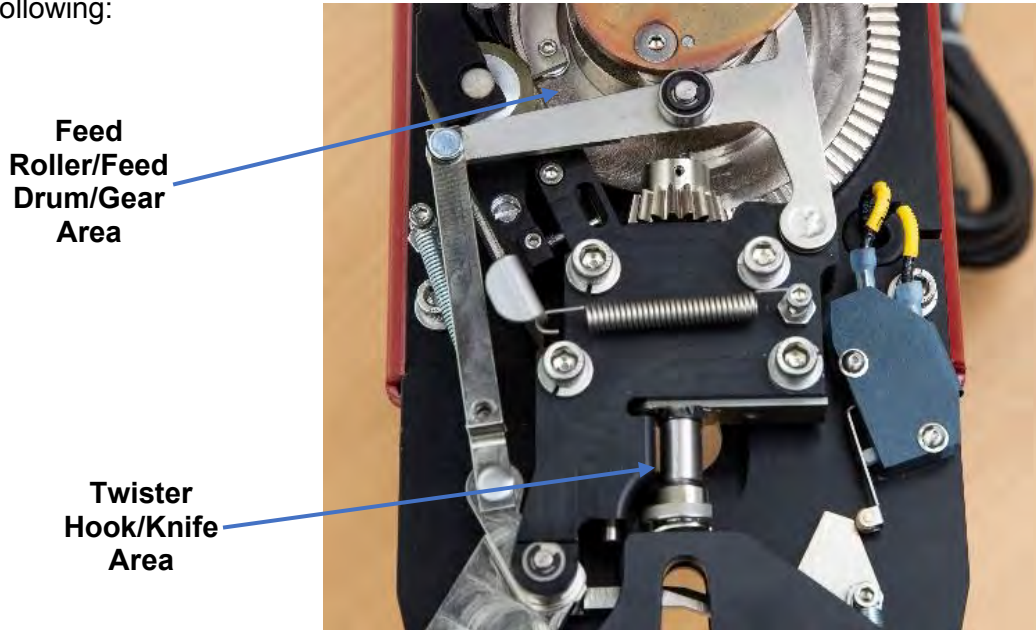

Figure 4.3.1 Jam Locations

Jam Occurred at Twister Hook	
Issue	Solution
1. Tie broke around bundle and material is left in twister hook.	1. Pull material out of twister hook. The throat plate may need to be removed to completely remove material. See <i>Figure 6.1.1</i> . Ensure there is no damage to the threaded tie material or the twister hook.
2. Tie length is too short not allowing twister hook to tie material around bundle.	2. Ensure machine is feeding properly. See 4.1 Setting the Tie Stop. Ensure there is no resistance present in the payout.
3. Tie is not feeding through twister hook.	3. Check for damage to pinion block assembly or twister hook. Ensure tie is not curved or kinked.
4. Tie is curving after twister hook and not aligning with pack arm end.	4. Adjust the feed roller closer to the center of gear/motor shaft. Adjust tie guide closer to the feed drum.

Jam Occurred at Feed Roller	
Issue	Solution
1. Tie material is curved, kinked, or damaged.	1. Pull material out of machine. Refer to Unthreading Tie Ribbon 2. in Section 2.3. A needle-nose pliers may be required. Ensure material is not damaged when stringing up.
2. Tie stop is not set to proper distance.	2. Set the tie stop. See 4.1 Setting the Tie Stop.

## 4.4 Setting the Drive Gear Height

(Reference Figure 4.4.1)

This operation is only necessary if the drive gear or motor is removed or replaced. The main drive gear is fastened to the motor shaft with a key and two set screws. The location of the drive gear must be set to the correct height on the motor shaft to ensure the gear teeth mesh properly with the pinion gear that rotates the twister hook and knife. Improper gear mesh can cause damage to the gears and motor as well as prevent the machine from cycling successfully.

1. Ensure the motor is fastened to the base plate properly. Refer to 6.8. Base Plate and Motor.
2. Reference 6.7 Tie Guide, Gear, and Cam for details regarding the assembly of the main drive gear and accessories.
3. Once the drive gear is installed on the motor shaft with the key and set screws. Use a shim or feeler gauge of 0.010" to set the distance between the drive gear and pinion gear flats. See *Figure 4.4.1*.

*NOTE: This distance should not be less than 0.005" and not greater than 0.015" in order to prevent damage.*

4. Once this distance is set, tighten the two set screws on the drive gear to the motor shaft to hold the gear height position.

*NOTE: Threadlocking compound should be used with the set screws to prevent them from loosening over time and causing gear teeth misalignment.*

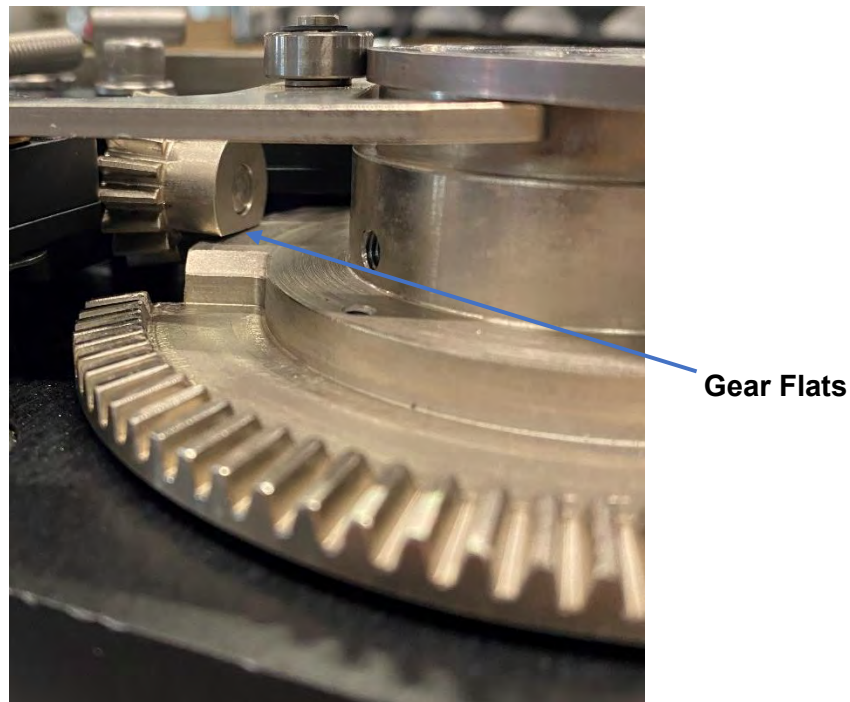

*Figure 4.4.1 Main Drive Gear and Pinion Flats*

## 5.0 Troubleshooting

(Reference Table 5.1 as a guide for troubleshooting)

**Table 5.1 Troubleshooting Chart**

<b>Problem</b>	<b>Possible Cause</b>	<b>Corrective Action</b>
Power on; Indicator light on, but no motor drive or machine operation	<ol style="list-style-type: none"> <li>Lid switch not engaged</li> <li>Trigger switch not engaging</li> <li>Cam switch not engaged</li> <li>Solid state timer not working properly (non-PLC machine only)</li> <li>PLC not working properly</li> <li>Motor not working properly</li> </ol>	<ol style="list-style-type: none"> <li>Ensure lid is closed and activating the lid switch. Switch may be bad and need replacing (<i>Figure 1.2.3.1</i>)</li> <li>Ensure trigger is activating the trigger switch. Switch may be bad and need replacing (<i>1.2.3.2</i>)</li> <li>Ensure cam is activating the cam switch when machine is at rest. Machine must be in correct position to start. Switch may be bad and need replacing (<i>Figure 1.2.3.3</i>)</li> <li>Replace timer inside machine</li> <li>Check input/outputs</li> <li>Replace motor</li> </ol>
Power on; no indicator light and no motor drive or machine operation	<ol style="list-style-type: none"> <li>Power supply blown</li> <li>Switch not working properly</li> <li>Cord/plug damaged</li> </ol>	<ol style="list-style-type: none"> <li>Consult factory</li> <li>Replace switch</li> <li>Replace cord/plug</li> </ol>
Machine cycles but does not stop	<ol style="list-style-type: none"> <li>Cam microswitch not working properly</li> <li>Solid state timer not working properly</li> <li>PLC not working properly</li> </ol>	<ol style="list-style-type: none"> <li>Replace microswitch. See Section 2 in Microswitches</li> <li>Replace timer</li> <li>Check input/output 3.1 Replace PLC</li> </ol>
Machine cycles but does not feed tie	<ol style="list-style-type: none"> <li>Tie material is not strung up properly</li> <li>Material cannot freely pull off spool/payout with ease</li> <li>Pivot arm spring is damaged or not connected</li> <li>Feed roller is damaged</li> <li>Feed drum is clogged or damaged</li> </ol>	<ol style="list-style-type: none"> <li>Follow string up directions and properly string up. See 2.3 Threading Tie Ribbon</li> <li>See below <ol style="list-style-type: none"> <li>Spool is damaged or material is snagged. Pull material off by hand and try again. Replace spool</li> <li>Payout brake is not releasing properly.</li> </ol> </li> <li>Connect or replace spring. See 6.1 Springs</li> <li>Replace feed roller. See 6.3 Feed Roller</li> <li>Clean or replace feed drum. See 6.5 6.5 Feed Drum</li> </ol>
Tie material jams near the feed roller and feed drum	<ol style="list-style-type: none"> <li>Tie stop is set too far in and preventing tie from feeding properly</li> <li>Tie material jammed at cutter knife or twister hook</li> <li>Tie material jammed in pinion block assembly</li> </ol>	<ol style="list-style-type: none"> <li>Set tie stop properly. See 4.1 Setting the Tie Stop</li> <li>Remove debris or damaged tie and ensure twister hook and cutter knife are in alignment</li> <li>Remove debris or tie material and try again</li> </ol> <p>See 4.3 Clearing a Jam</p>

<p>Tie material is feeding too short</p> <p>Tie Lengths per Model:</p> <p>3/8" – 3.75" 5/8" – 4.125</p>	<ol style="list-style-type: none"> <li>1. Feed roller is damaged</li> <li>2. Feed drum is clogged or damaged</li> <li>3. Tie material is not freely pulling off payout</li> </ol>	<ol style="list-style-type: none"> <li>1. Replace feed roller. See 6.3 Feed Roller</li> <li>2. Clean or replace feed drum. See 6.5 6.5 Feed Drum</li> <li>3. See below             <ol style="list-style-type: none"> <li>3.1. Spool is damaged or material snagged. Pull material off by hand and try again. Replace spool</li> <li>3.2. Payout arm not releasing properly. See section 5 in Springs</li> </ol> </li> </ol>
<p>Machine does not complete a full cycle</p>	<ol style="list-style-type: none"> <li>1. Solid state timer not working properly</li> <li>2. Lid switch is not working properly</li> <li>3. Machine jam due to debris in gear teeth</li> <li>4. Pack arm jamming</li> <li>5. Gears colliding/not meshing properly</li> </ol>	<ol style="list-style-type: none"> <li>1. Replace timer</li> <li>2. Ensure lid is engaging switch. Replace switch. See 6.2 Microswitches</li> <li>3. Thoroughly clean machine and gears</li> <li>4. Ensure bundle is not in the path of the pack arm</li> <li>5. Ensure main drive gear height is set correctly. See 4.4 Setting the Drive Gear Height</li> </ol>
<p>Trigger does not return</p>	<ol style="list-style-type: none"> <li>1. Trigger spring is damaged</li> </ol>	<ol style="list-style-type: none"> <li>1. Replace spring. See 6.1 Springs</li> </ol>
<p>Tie is not cut or has a rugged cut</p>	<ol style="list-style-type: none"> <li>1. Cutter knife or anvil is damaged</li> <li>2. Cutter spring is damage</li> </ol>	<ol style="list-style-type: none"> <li>1. Replace cutter knife and anvil. See 6.4 Pinion Block Assembly and Linkages</li> <li>2. Replace spring. See 6.4 Pinion Block Assembly and Linkages</li> </ol>
<p>Payout over runs tie material</p>	<ol style="list-style-type: none"> <li>1. Brake is worn or damaged</li> <li>2. Payout spring is damaged</li> <li>3. Spool is too full</li> </ol>	<ol style="list-style-type: none"> <li>1. Replace brake pad. See 6.10 Payout</li> <li>2. Replace spring. See 6.1 Springs</li> <li>3. Pull material off by hand and try again. This is possible if extra tie footage is present on the spool and the brake does not stop the spool before tie can fall off the spool flanges</li> </ol>
<p>Tie material jams near twister hook or is not being properly wrapped by pack arm</p>	<ol style="list-style-type: none"> <li>1. Tie guide and/or feed drum is not properly adjusted</li> </ol>	<ol style="list-style-type: none"> <li>1. Move the feed drum closest to the gear center/motor shaft. Adjust the tie guide to be close to the feed drum without touching the feed drum</li> </ol>



## 6.0 Parts

*Warning: Remove the cord from the outlet before attempting any of these procedures. Use proper lock-out procedures if the machine will be left unattended.*

Please contact Bedford Industries for spare parts inquiries.

When ordering parts, locate the machine nameplate (*example shown in Figure 6.1*) and provide the model, model number, and serial number with your request for parts. This information will aid in providing quick and accurate service from Bedford Industries.



*Figure 6.1 Machine Nameplate*

## 6.1 Springs

(Reference Figure 6.1.1, Figure 6.1.2, Figure 6.1.3, & Figure 6.1.4)

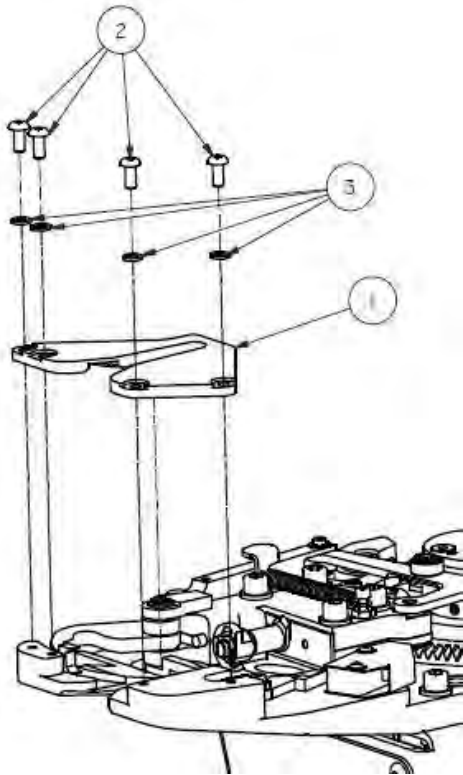

Figure 6.1.1 Throat Plate

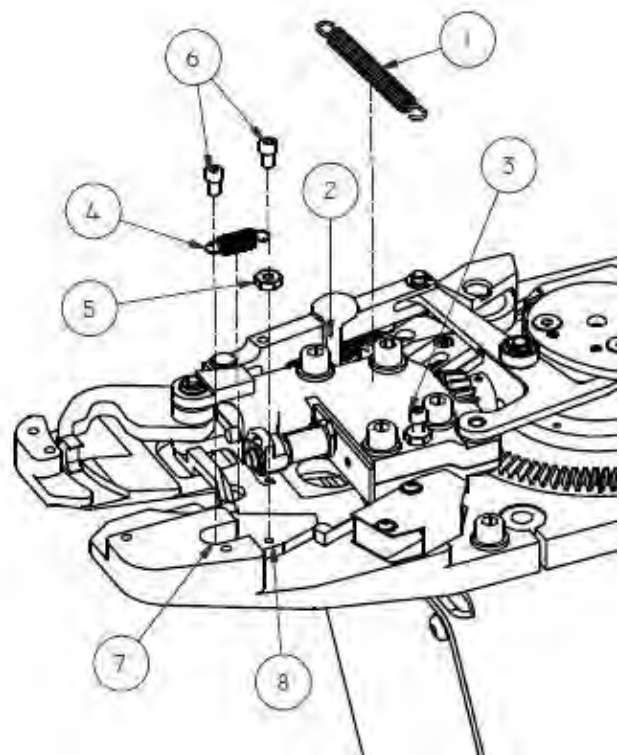

Figure 6.1.2 Trigger and Pivot Arm Springs

There are five springs located on the Mini Tyer Pro. See the list and figures below for location and how to remove/replace them.

1. Pivot arm spring (1, Figure 6.1.2) – This spring puts pressure on the pivot arm and allows the feed roller to pinch tie material against the feed drum.
  - 1.1 To remove, grab the spring and unhook it from the fastener (3, Figure 6.1.2) attached to the pinion block assembly. Then unhook the other end from the pivot bracket (2, Figure 6.1.2) on the pivot arm. (A needle-nose pliers may be useful to do this)  
  
When attaching the spring, ensure the hooks are attached properly and the spring is straight and not rubbing on the pinion block.
2. Trigger spring (4, Figure 6.1.2) – This spring pulls the trigger back to its starting position.
  - 2.1. To remove, the throat plate (1, Figure 6.1.1) will need to be removed.
  - 2.2. Remove the cap head screw (6, Figure 6.1.2) located under the throat plate attached to the base plate.
  - 2.3. Remove the cap head screw (6, Figure 6.1.2) located on the trigger. The hex nut (5, Figure 6.1.2) will need to be loosened first before the screw will loosen.  
  
When attaching the spring, ensure the cap head screws (6, Figure 6.1.2) are not tightened too tight and pinch the spring or spring hooks. This could cause damage and premature wear.  
  
Also, ensure the hex nuts are tightened properly so the screws do not come loose.

3. Pack arm spring (1, Figure 6.1.3) – This spring pulls the pack arm back to its starting position and puts pressure on the linkages allowing the bearing on the actuator weldment to contact the cam.

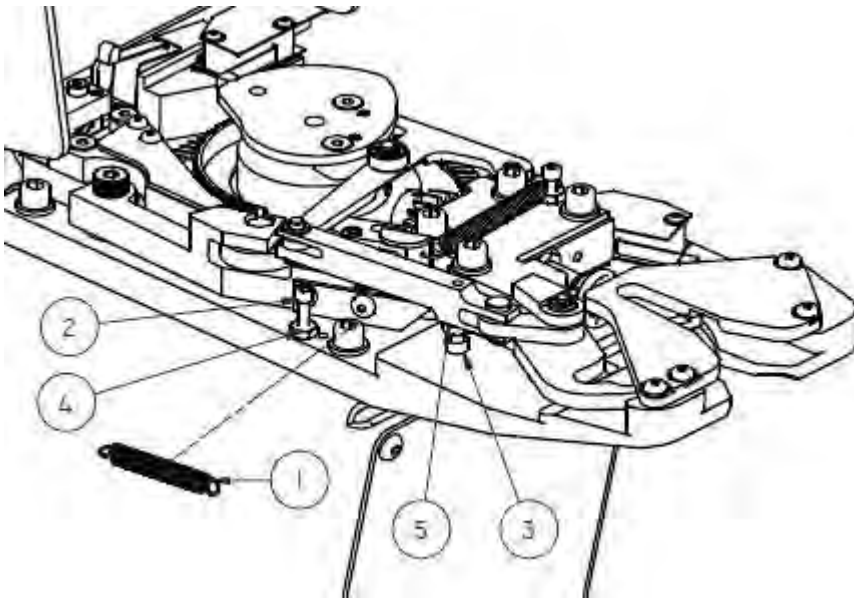

Figure 6.1.3 Pack Arm Spring

3.1. To remove, use needle-nose pliers to unhook the spring from the fastener (3, Figure 6.1.3) attached to the bottom of the linkage as well as the fastener (2, Figure 6.1.3) attached to the base plate.

When attaching the spring, ensure the hooks are properly attached and the spring is straight and not rubbing the base plate or any fasteners.

Ensure the hex nuts are tightened properly so the fasteners do not come loose.

4. Cutter knife spring – This compression spring puts pressure between the twister hook and the knife. It is located on the pinion shaft.

4.1. To remove, see Pinion Block Assembly (Reference Figure 6.4.3)

5. Payout spring (1, Figure 6.1.4) – This spring puts pressure on the brake pad allowing the pad to stop the spool from unwinding during operation.

5.1. To remove, disconnect the hook ends from the threaded anchors (2, 3, Figure 6.1.4) attached to the payout arm and brake pad. Needle-nose pliers may be useful to do this

When attaching the spring, ensure the hook ends are attached properly.

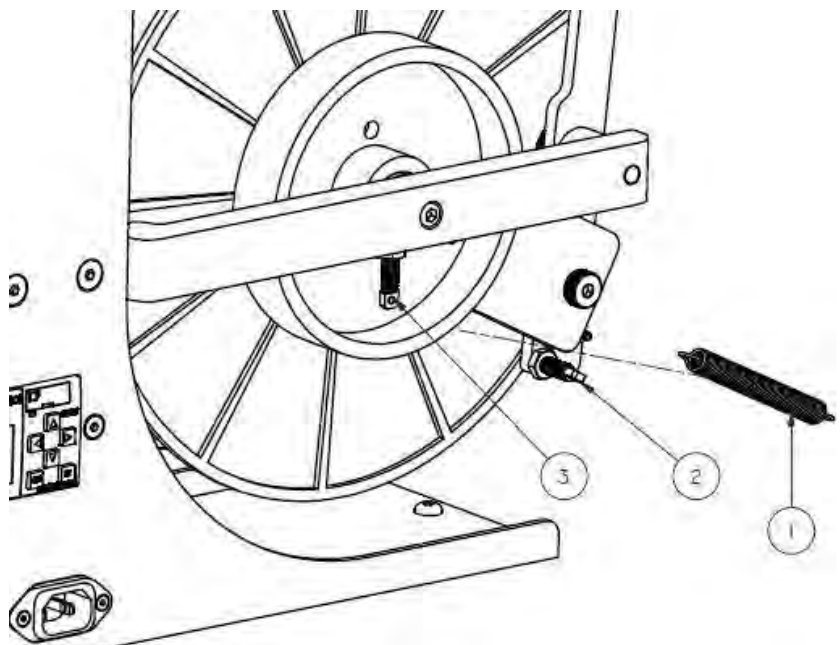

Figure 6.1.4 Payout Spring



## 6.2 Microswitches

(Reference Figure 6.2.1, Figure 6.2.2, & Figure 6.2.3)

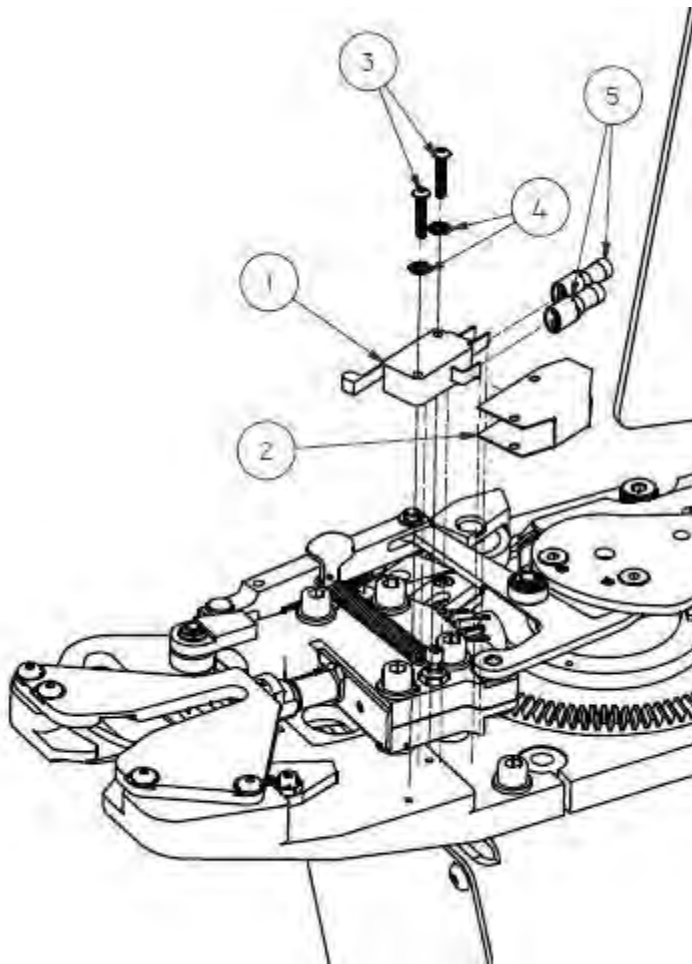

Figure 6.2.1 Trigger Switch

### 1. Trigger Switch (Reference Figure 6.2.1)

- 1.1 To remove, unfasten the two button head screws (3) located on top of the switch (1).
- 1.2 Disconnect the two electrical wires with the quick connect plugs (5). Be sure not to pull the wire out of the plug.

NOTE: Do not damage or discard the cover (2) around the switch. It is non-conductive and a safety cover to prevent accidental shock from the electrical wiring.

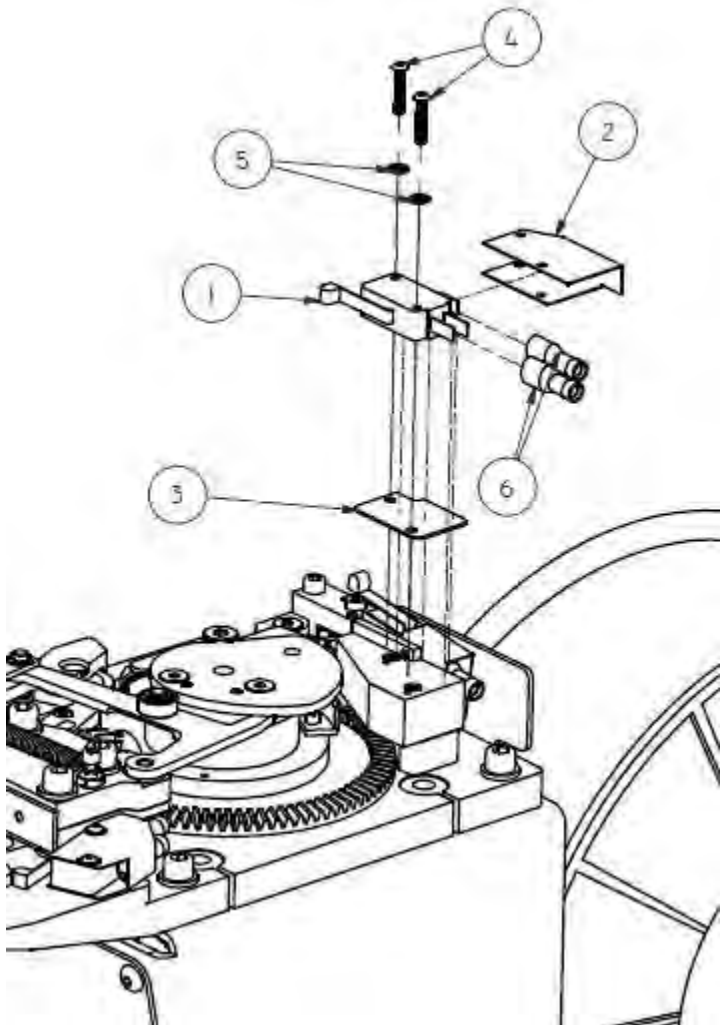

Figure 6.2.2 Cam Switch

### 2. Cam Switch (Reference Figure 6.2.2)

- 2.1 To remove, unfasten the two button head screws (4) located on top of the switch (1).
- 2.2 Disconnect the two electrical wires with the quick connect ends (6). Be sure not to pull the wire out of the end.

NOTE: Do not damage or discard the cover (2) around the switch. It is non-conductive and a safety cover to prevent accidental shock from the electrical wiring.

### 3. Lid Switch (Reference Figure 6.2.3)

3.1 To remove, the cam switch needs to be removed first. See the directions above in section 2 *Cam Switch* to remove the cam switch.

3.2 Next, the switch block (1) should be removed. Under the cam switch are two cap head screws (2) that fasten the switch block to the base plate. Loosen and remove the two screws.

3.3 The switch block and lid switch should be free from the base plate and the button head screws (5) holding the lid switch (3) on the block can be removed.

3.4 Disconnect the two electrical wires with the quick connect ends (7). Be sure not to pull the wire out of the end.

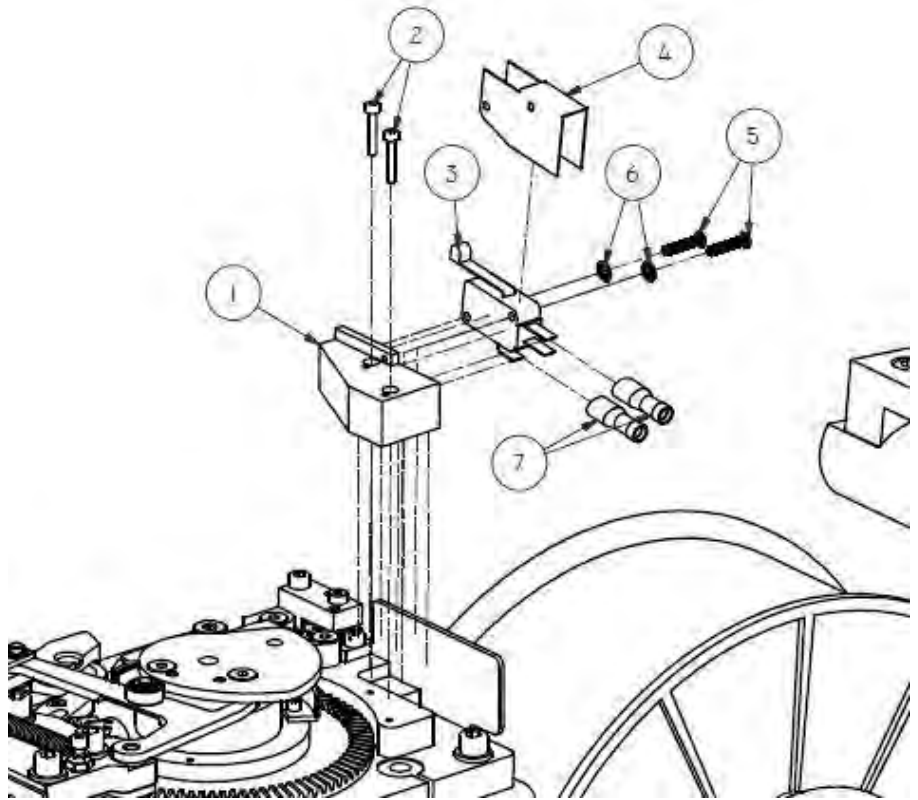

Figure 6.2.3 Lid Switch

NOTE: Do not damage or discard the cover (4) around the switch. It is non-conductive and a safety cover to prevent accidental shock from the electrical wiring.



## 6.4 Pinion Block Assembly and Linkages

(Reference Figure 6.4.1, Figure 6.4.2 & Figure 6.4.3)

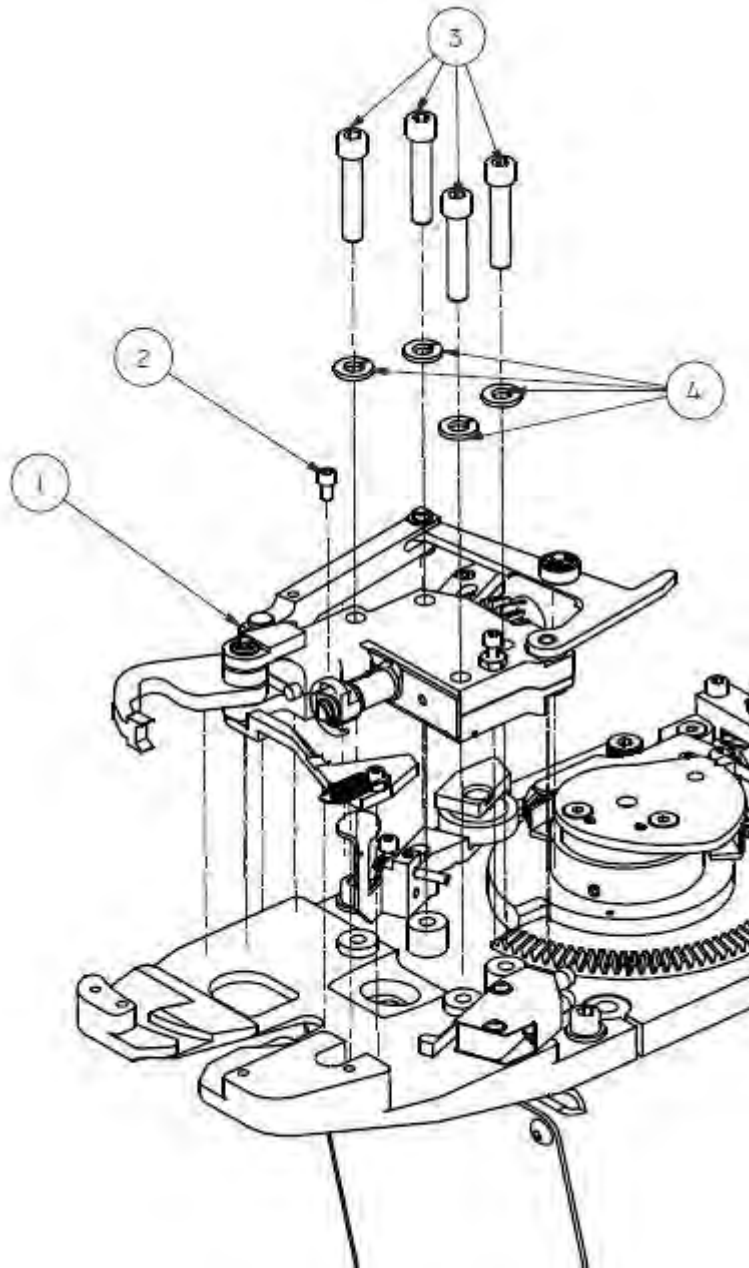

### Removal from Base Plate

1. The pinion block assembly and attached linkages must be removed together.
2. First, the throat plate must be removed. Reference *Figure 6.1.1*.
3. Next, disconnect the pivot arm spring. Reference *Figure 6.1.2* and *Pivot arm spring* in *Section 6.1 Springs*
4. Then, disconnect the trigger spring from the base plate. Remove the cap head screw (2) to do this.
5. Now, loosen and remove the four cap head screws (3) and lock washers (4) from the base plate.
6. The pinion block assembly and linkages (1) should be free to remove from the base plate.

Figure 6.4.1 Pinion Block and Linkages Removal

## Linkages (Reference Figure 6.4.2)

### 1. Trigger

- 1.1. Remove the retaining clip (14) at the top of the trigger pin.
- 1.2. The trigger weldment (15) will then slide out of the pinion sleeve (13) and the sleeve can be removed from the pinion blocks (1).
- 1.3. The trigger spring (16) can be removed by loosening the hex nut (18) and removing the cap head screw (17).

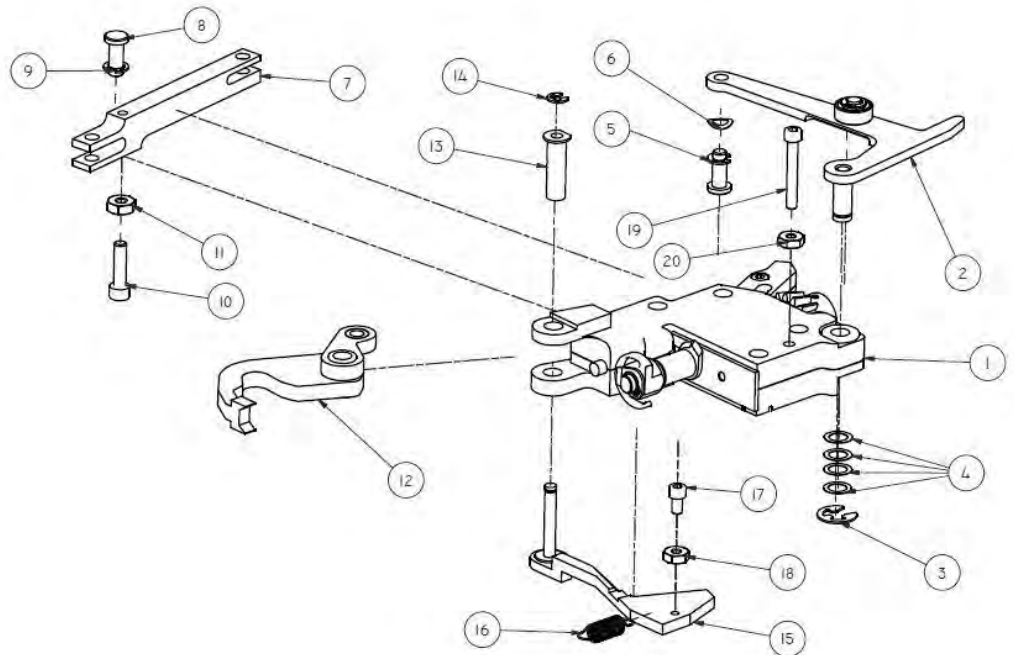

Figure 6.4.2 Linkage Removal from Pinion Block

### 2. Pack Arm

- 2.1. Remove the retaining clip (9) from the pin that connects the pack arm (12) and linkage (7). The pin can then be removed along with the wavy spring washer.
- 2.2. The pack arm (12) can then be removed from the assembly.

### 3. Linkage

- 3.1. Remove the retaining clip (5) from the pin that connects the linkage to the actuator weldment. The pin can then be removed along with the wavy spring washer (6).
- 3.2. The linkage (7) is now free. The cap head screw (10) that holds the pack arm spring in place can be removed by loosening the hex nut (11) and removing the screw.

### 4. Actuator Weldment

- 4.1. Remove the retaining clip (3) from the bottom of the actuator weldment (2). There are four shim washers (4) located there that should be removed also.
- 4.2. The actuator weldment (2) can be removed from the pinion block (1).

## Pinion Block Assembly (Reference Figure 6.4.3)

**NOTE:** The cutter knife spring (18) is located on the pinion shaft. The assembly must be disassembled to access it.

1. To access parts within the pinion block assembly, it must be disassembled.
2. Remove the cap head screw (16) located on the top of the top pinion support (1) from the bottom pinion support (2).
3. The top and bottom pinion supports should pull apart as shown. NOTE: the bushing (3) is only pressed into the top pinion support (1) and should have a loose fit with the bottom support (2).
4. The cushion (10) and pin (11) can be removed from the groove.
5. The pinion shaft assembly can be disassembled or removed then disassembled. The locator pin (12) will be free to remove.
6. To disassemble the pinion shaft assembly, remove the retaining clip (17). NOTE: Components on the pinion shaft assembly are under tension from the compression spring (18). Be sure to hold the components tight on the shaft when removing the retaining clip (17).
7. Once the clip is removed, the deflector (15), twister hook (14), spring cover (13), spring (18), cutter knife (8), and anvil (9) can be removed separately.
8. From the shaft, the bushing (4) and the bearing (5) can be removed.

**NOTE:** The pinion gear (7) is attached to the shaft and is sold as a complete part.

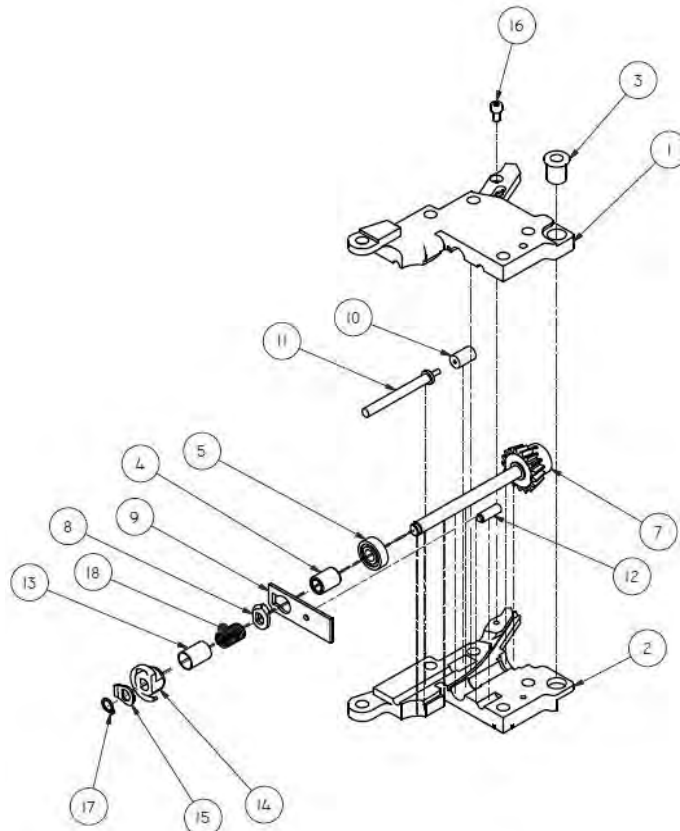

Figure 6.4.3 Pinion Block Assembly

## 6.5 Feed Drum

(Reference Figure 6.5.1)

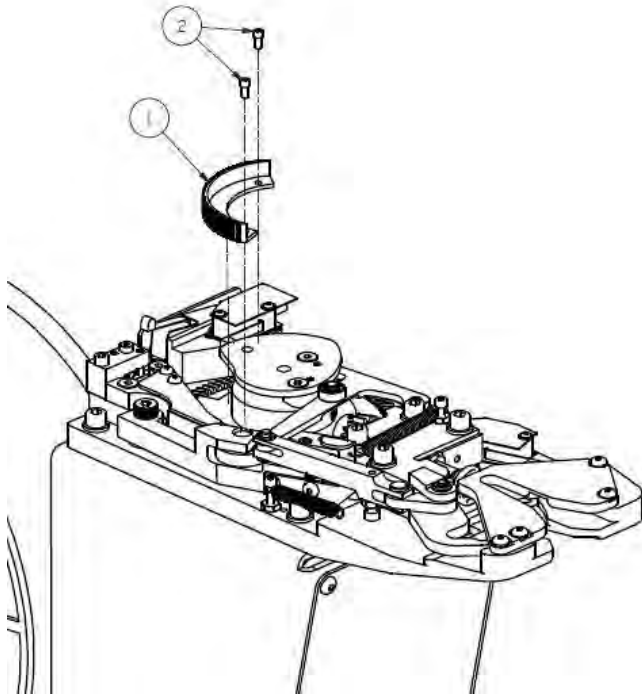

Figure 6.5.1 Feed Drum Removal

1. Remove the two cap head screws (2) located on top of the feed drum (1) that fasten into the top of the bevel gear.
2. The feed drum is then free to remove.

NOTE: There is a hole in the cam that can be used to reach the cap screw without removing the cam or gear.

## 6.6 Front and Rear Covers

(Reference Figure 6.6.1)

1. To remove the front cover (1), unfasten the four button head screws (2).
2. To remove the rear cover (3), unfasten the four button head screws (4, 5).

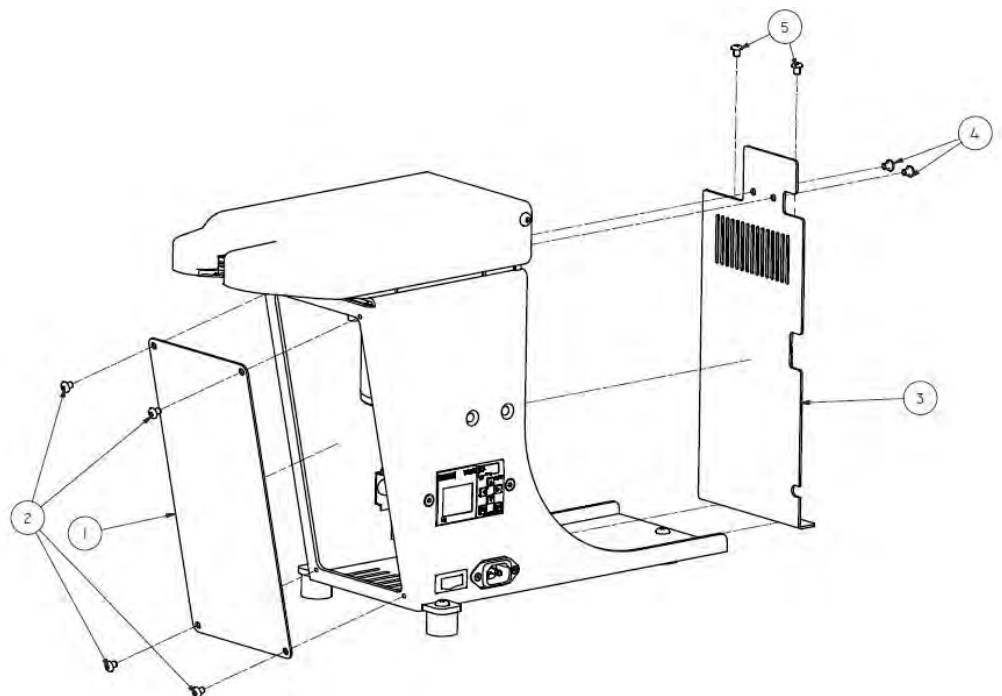

Figure 6.6.1 Front and Rear Cover Removal

## 6.7 Tie Guide, Gear, and Cam

(Reference Figure 6.7.1 & Figure 6.7.2)

### Tie Guide and Cover (Reference Figure 6.7.1)

1. The tie guide cover (3) can be removed if there is an issue with jamming or debris within the tie guide (1).
2. To remove, unfasten the two button head screws (4) and remove the cover (3).
3. To remove the tie guide (1), unfasten the two flat head screws (2) and remove the tie guide.

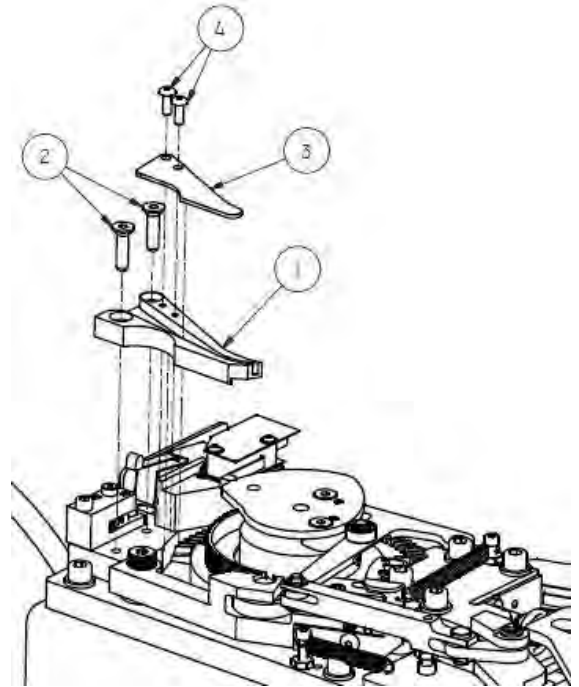

Figure 6.7.1 Tie Guide and Cover

### Cam and Gear (Reference Figure 6.7.2)

1. The cam (5) can be removed without removing the gear (1).
  - 1.1. Unfasten the two flat head screws (6)
  - 1.2. Remove the cam by gently prying it off the gear and out of the dowel pins (4).
2. To remove the bevel drive gear (1), most components must be removed from the base plate including the throat plate, pinion block assembly and linkages, pivot arm assembly, tie guide and cover, cam switch, and switch block with the lid switch.
3. Once the necessary components have been removed, the gear can be removed by loosening the two set screws (2) that hold the gear in place on the motor shaft.
4. The gear can be removed from the motor shaft by lifting it straight up off the shaft.  
NOTE: there is a key (3) that holds the motor shaft and gear in position.

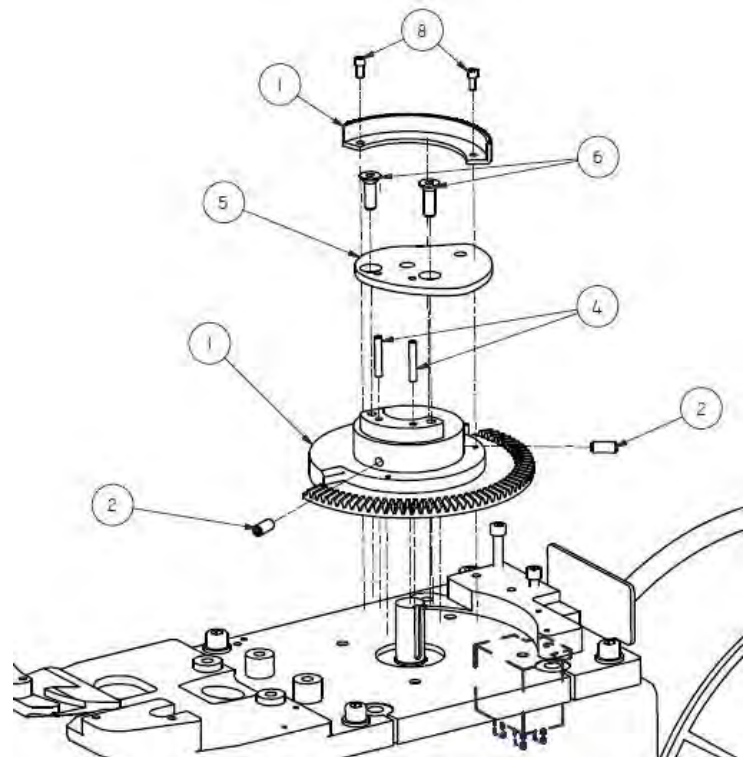

Figure 6.7.2 Gear, Cam, and Feed Drum

**NOTE:** When reassembling, the bevel drive gear must be positioned so there is 0.010" distance between the flats of the bevel and pinion gears. The pinion block assembly will need to be attached to set the gear height. Reference section 4.4 Setting the Drive Gear Height.



## 6.8 Base Plate and Motor

(Reference Figure 6.8.1)

NOTE: All electrical wires from the motor and capacitor should be disconnected before removing the base plate and motor.

### 1. Base Plate

1.1. To remove the base plate (1), loosen and remove the four cap head screws (2) and lock washers (3). The base plate and motor will be free to move.

### 2. Motor and Capacitor

1.1. To remove the capacitor (5), unfasten the screw (6) from the base plate.

1.2. To remove the motor, unfasten the four cap head screws (8) from the base plate and the motor will detach from the base plate.

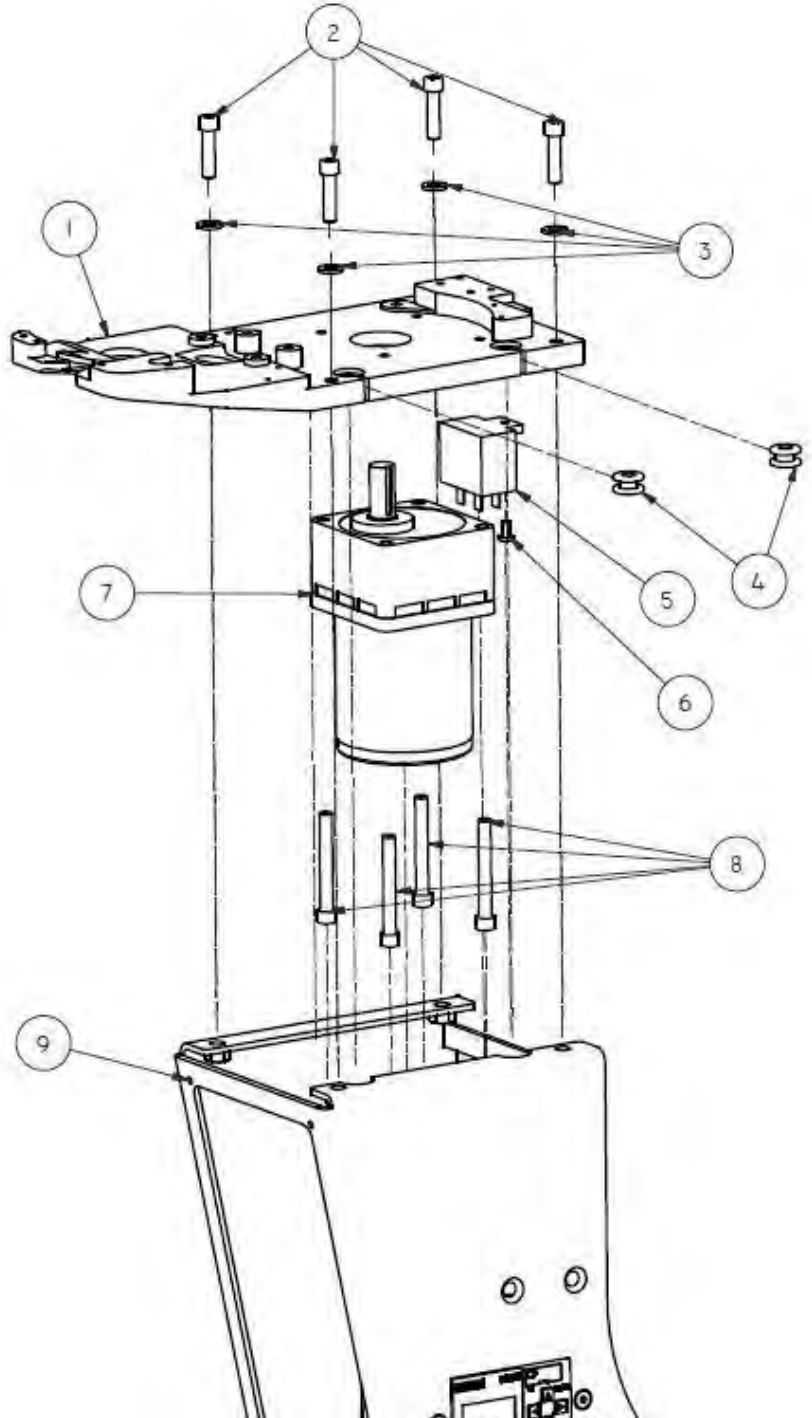

Figure 6.8.1 Base Plate and Motor Removal

## 6.9 Anti-Backup Assembly

(Reference Figure 6.9.1 & Figure 6.9.2)

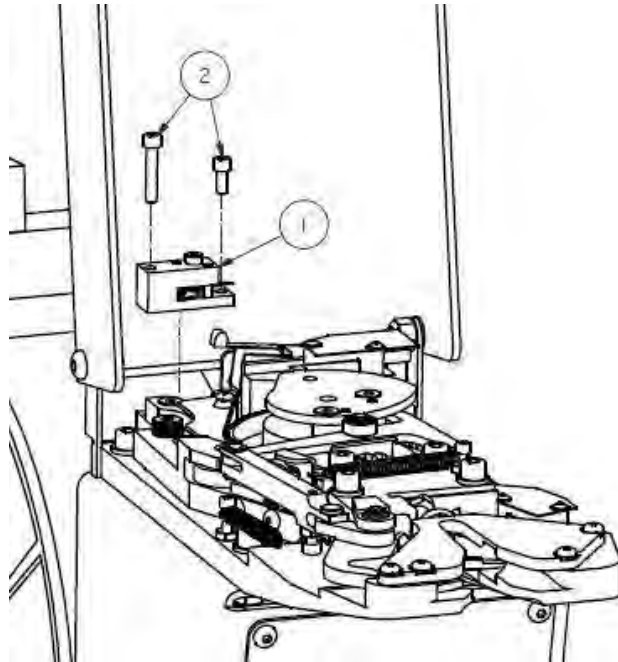

Figure 6.9.1 Anti-Backup Removal

1. To remove the anti-backup assembly (1), unfasten the two cap head screws (2) and remove the assembly.

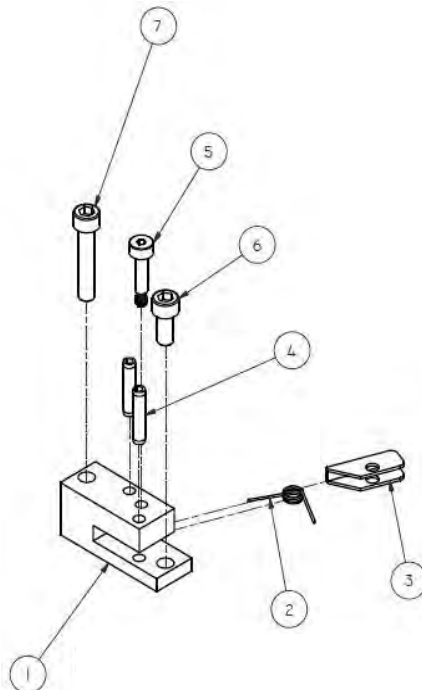

Figure 6.9.2 Anti-Backup Assembly

2. To remove the anti-backup arm (3) or spring (2), unfasten the shoulder bolt (5). Note that the spring is under tension and can eject from the assembly without the bolt holding it in place.

## 6.10 Payout

(Reference Figure 6.10.1)

1. To remove the payout (1), remove the two flat head screws (2) from the right side of the machine. Be sure to hold the payout and release the pressure on the screws.
2. The payout assembly will completely slide out to the rear from the machine frame.

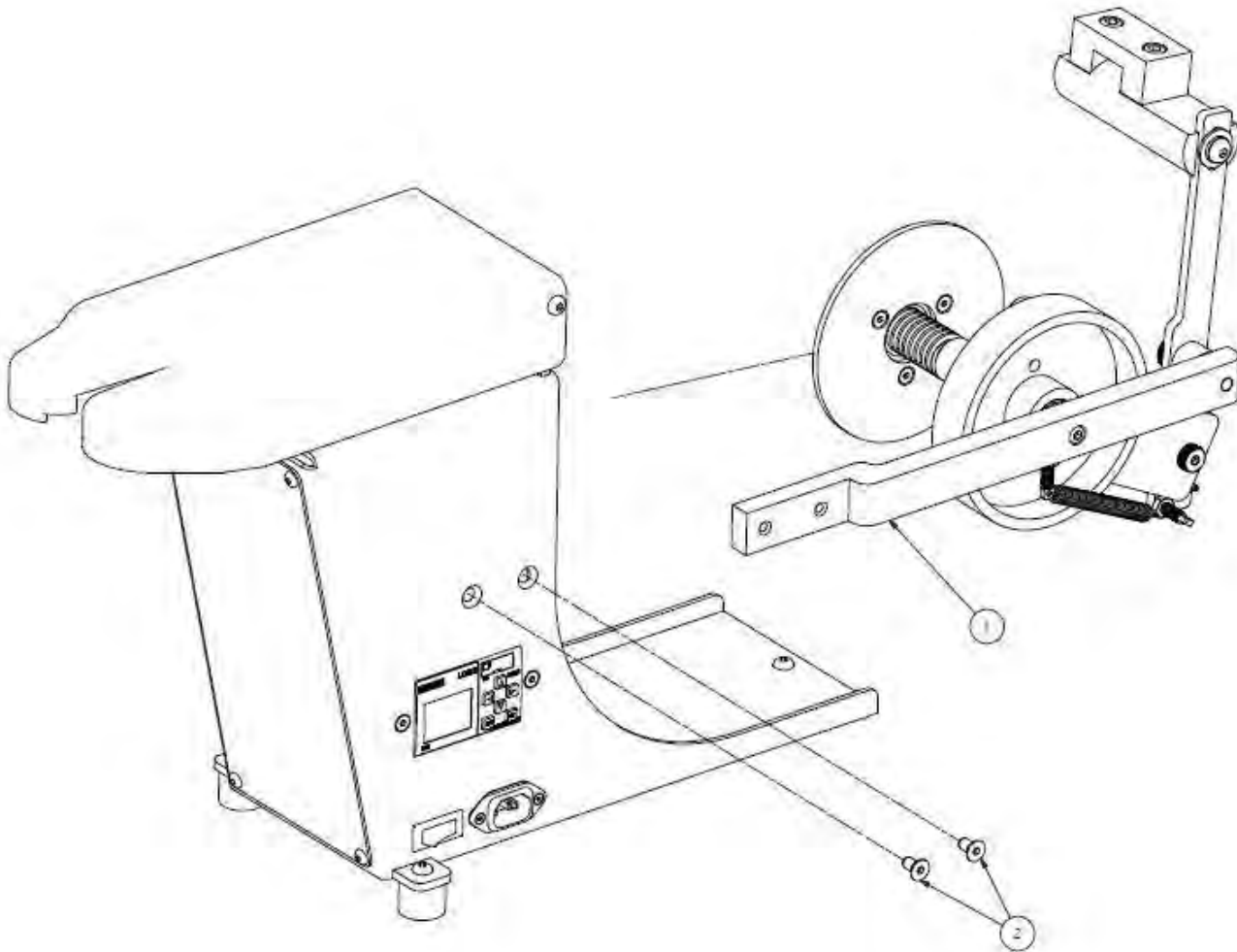

Figure 6.10.1 Payout Removal



# 7.0 Drawings and Parts Lists

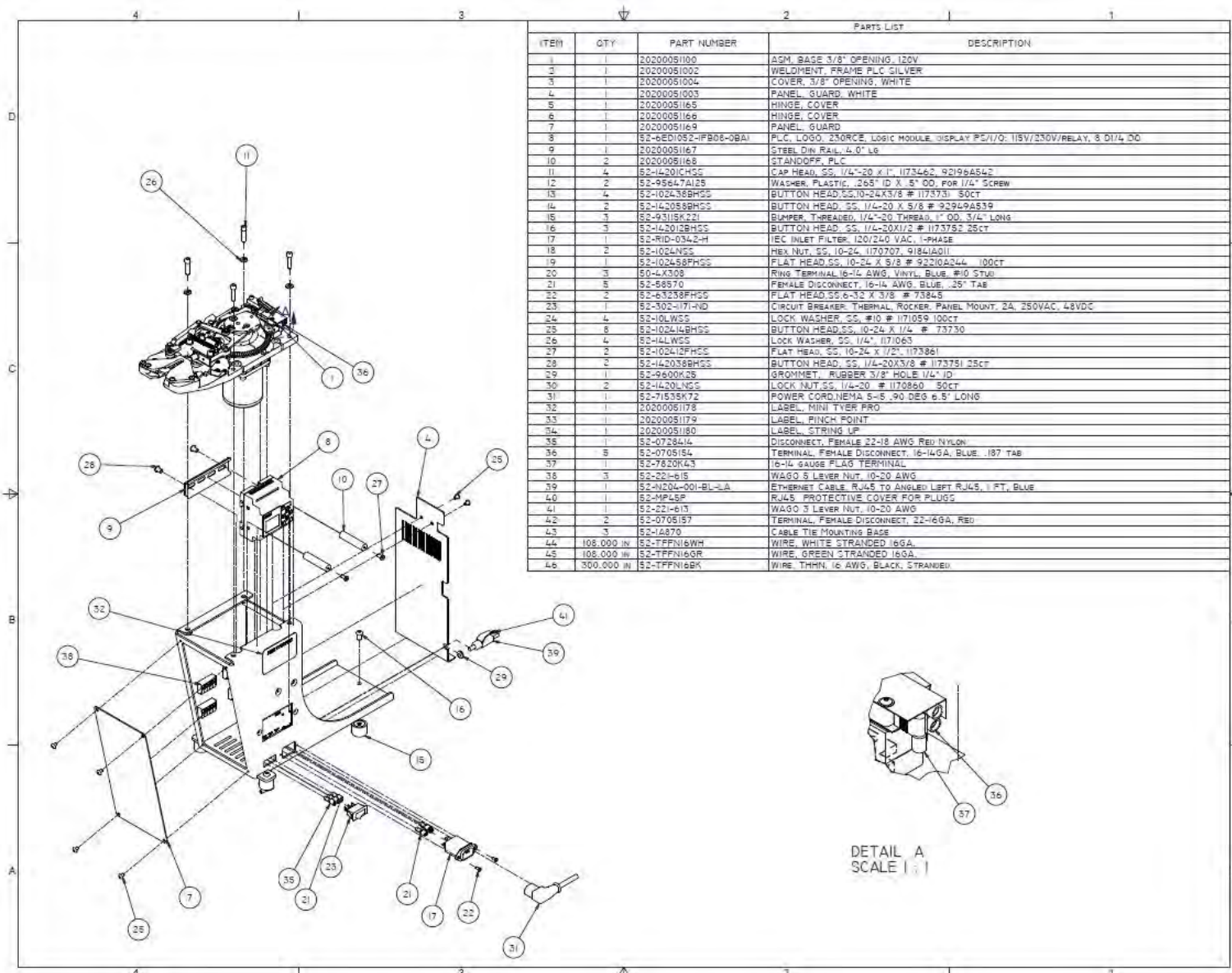

Figure 7.1 Drawing 2020051000 View 1 (3/8" Model, 120VAC)

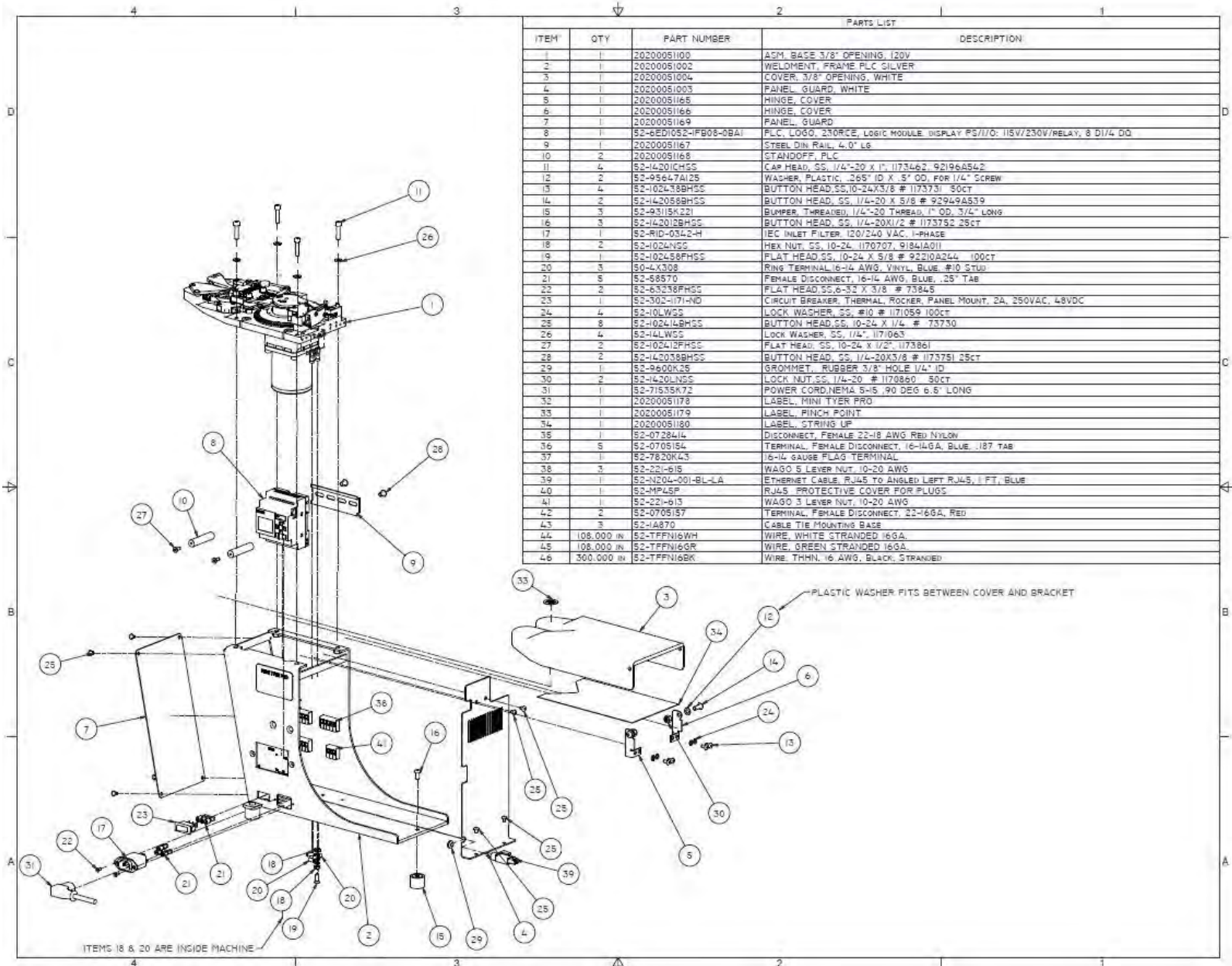

Figure 7.2 Drawing 20200051000 View 2 (3/8" Model, 120VAC)

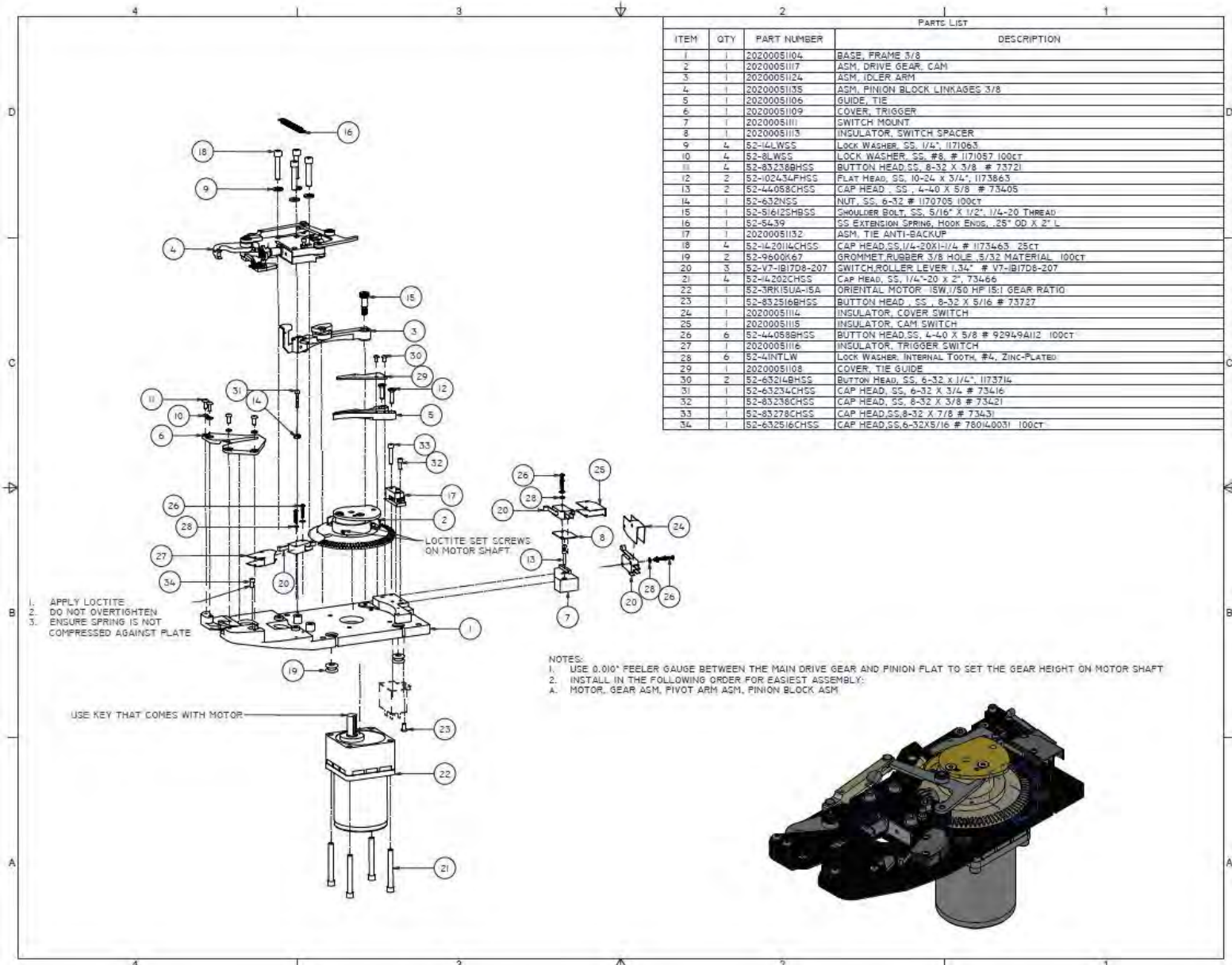

Figure 7.3 Drawing 20200051100 (3/8" Model, 120VAC)

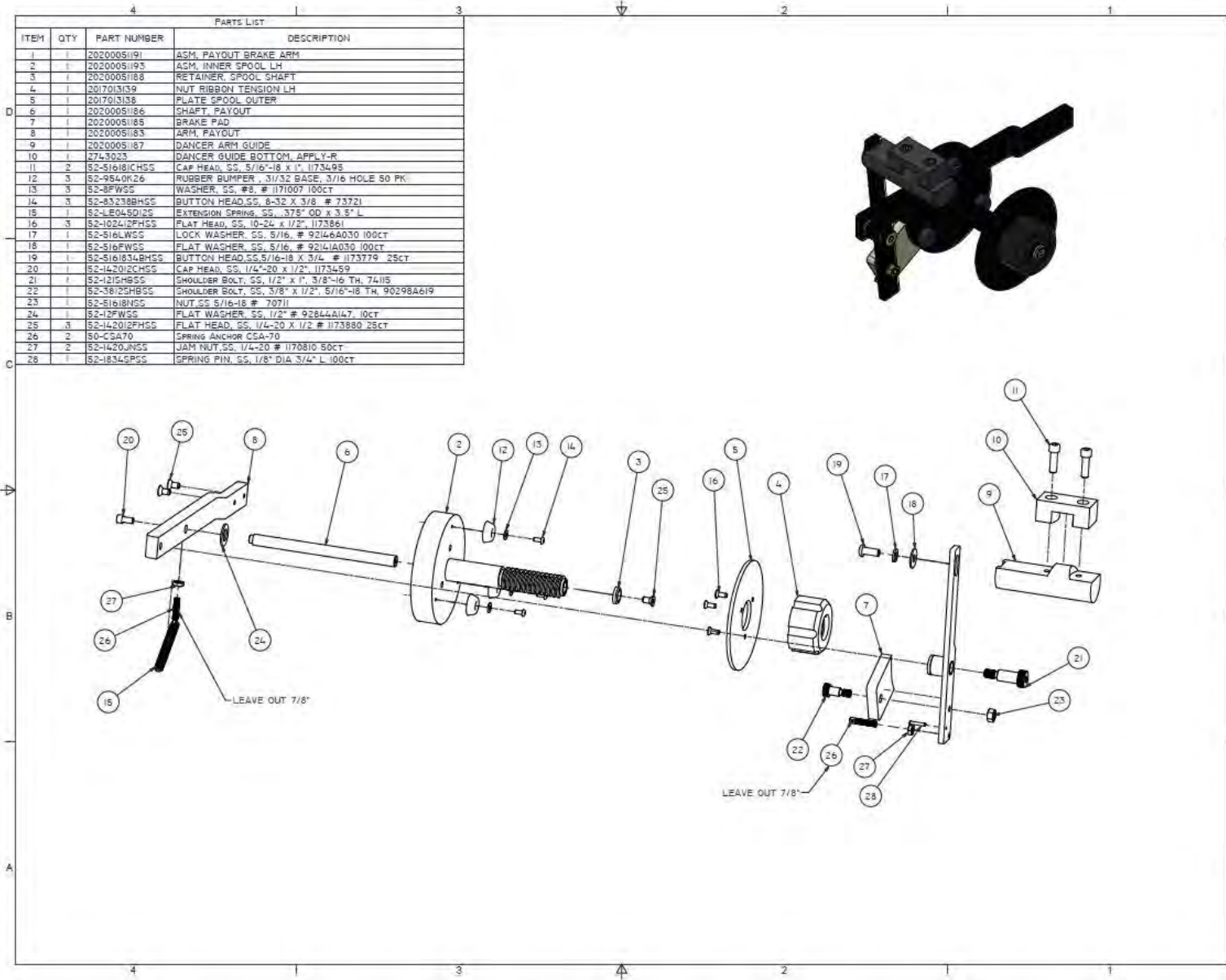

Figure 7.4 Drawing 20200051181 (All Models)

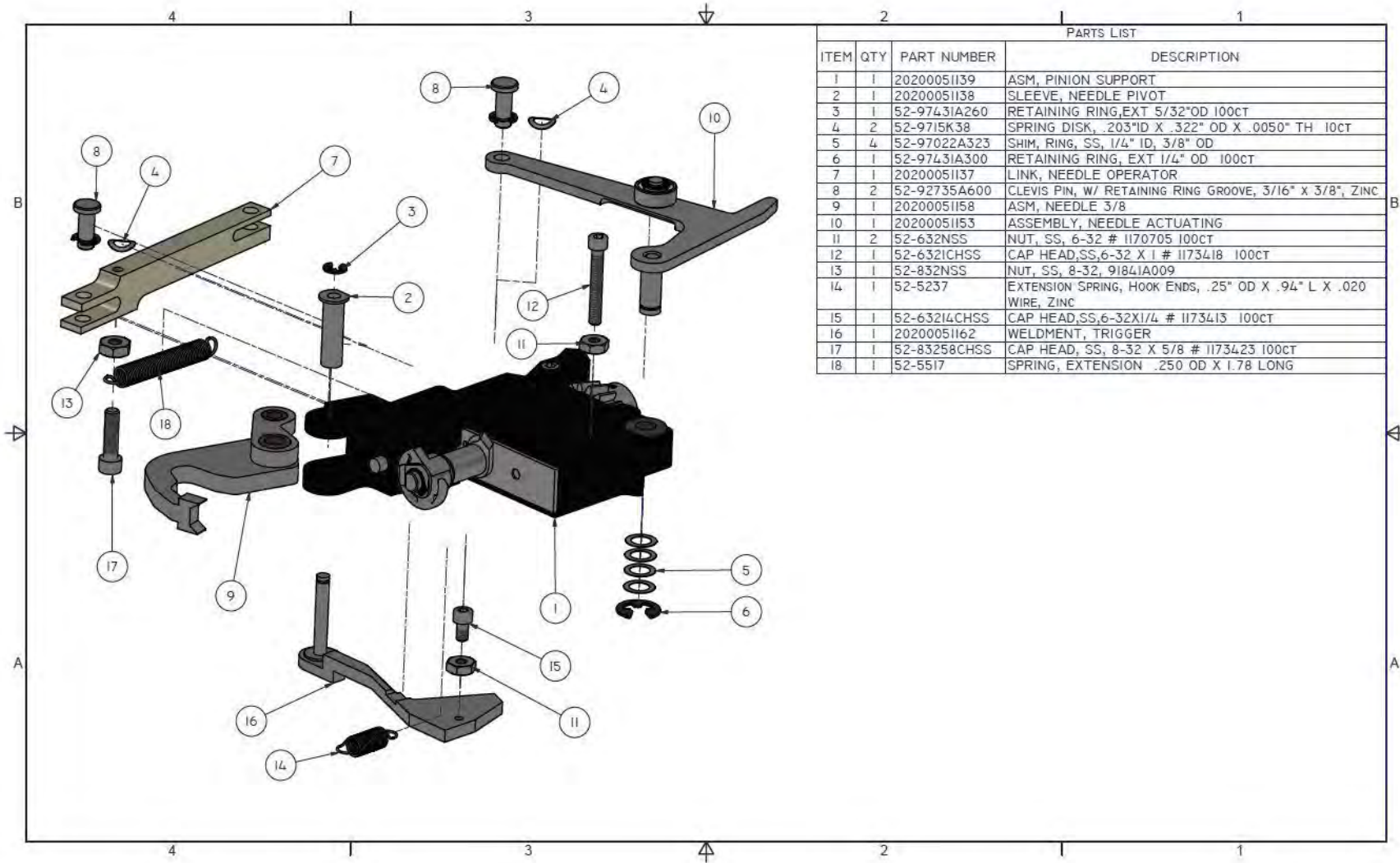

Figure 7.5 Drawing 20200051135 (3/8" Model)



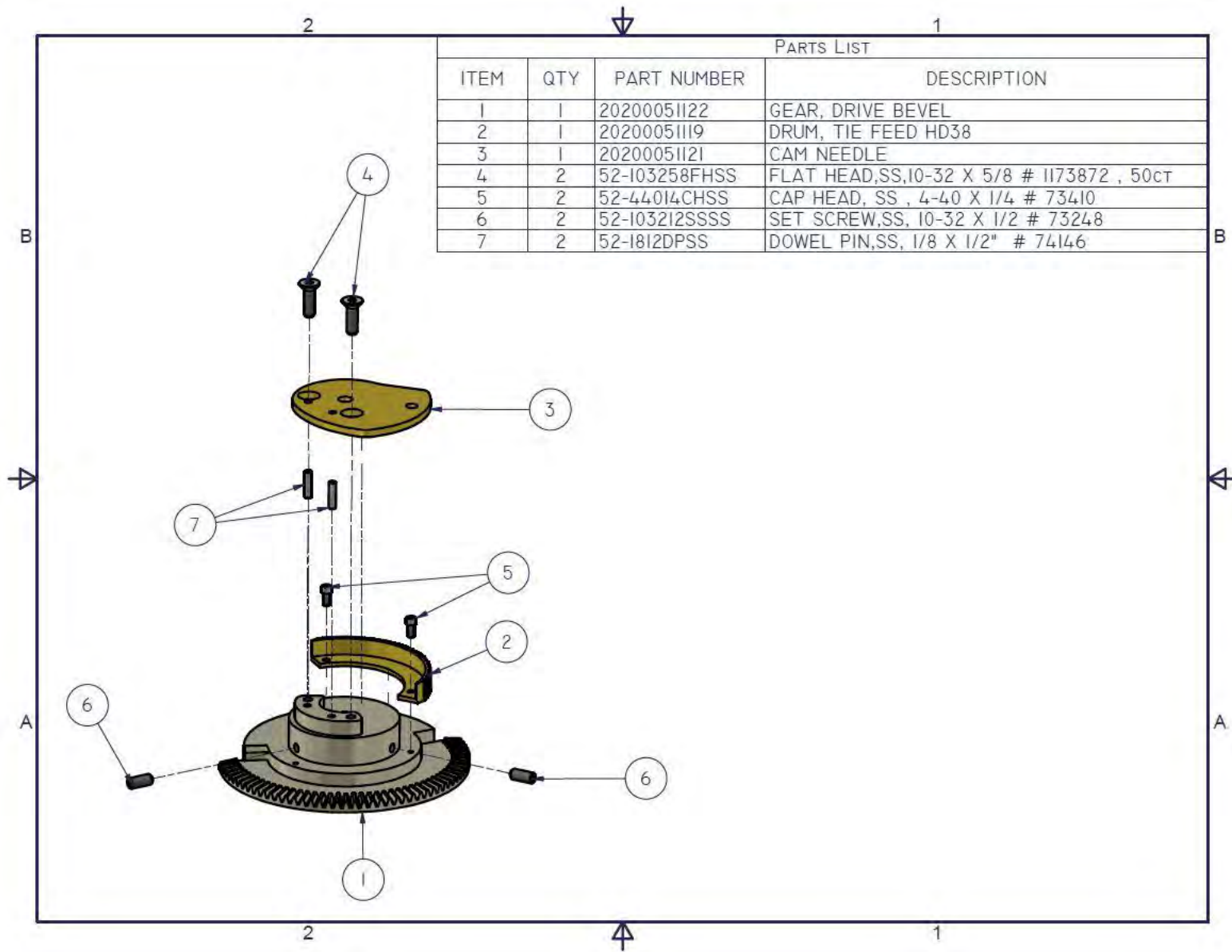

Figure 7.6 Drawing 20200051117 (3/8" Model)

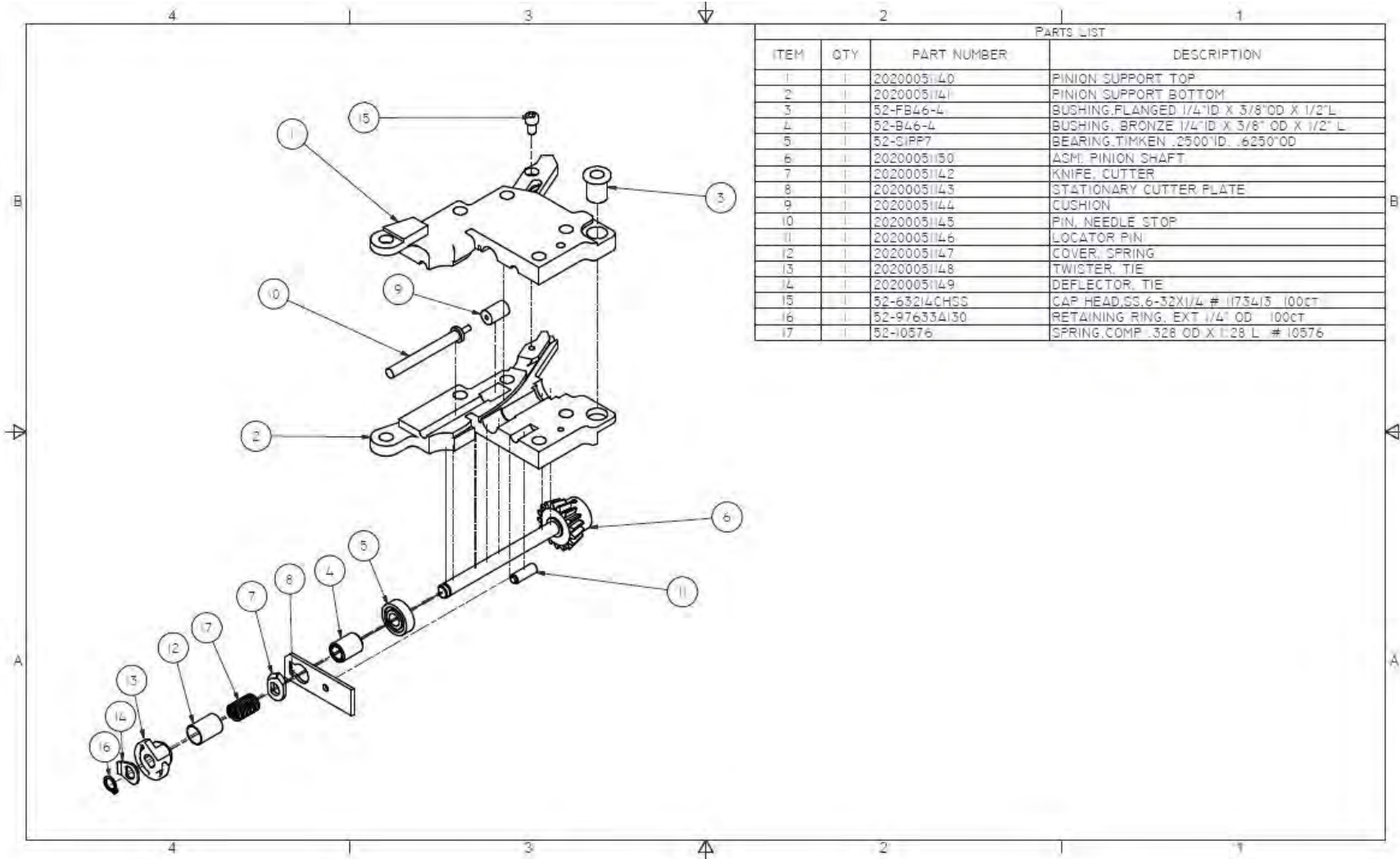

Figure 7.7 Drawing 20200051139 (All Models)



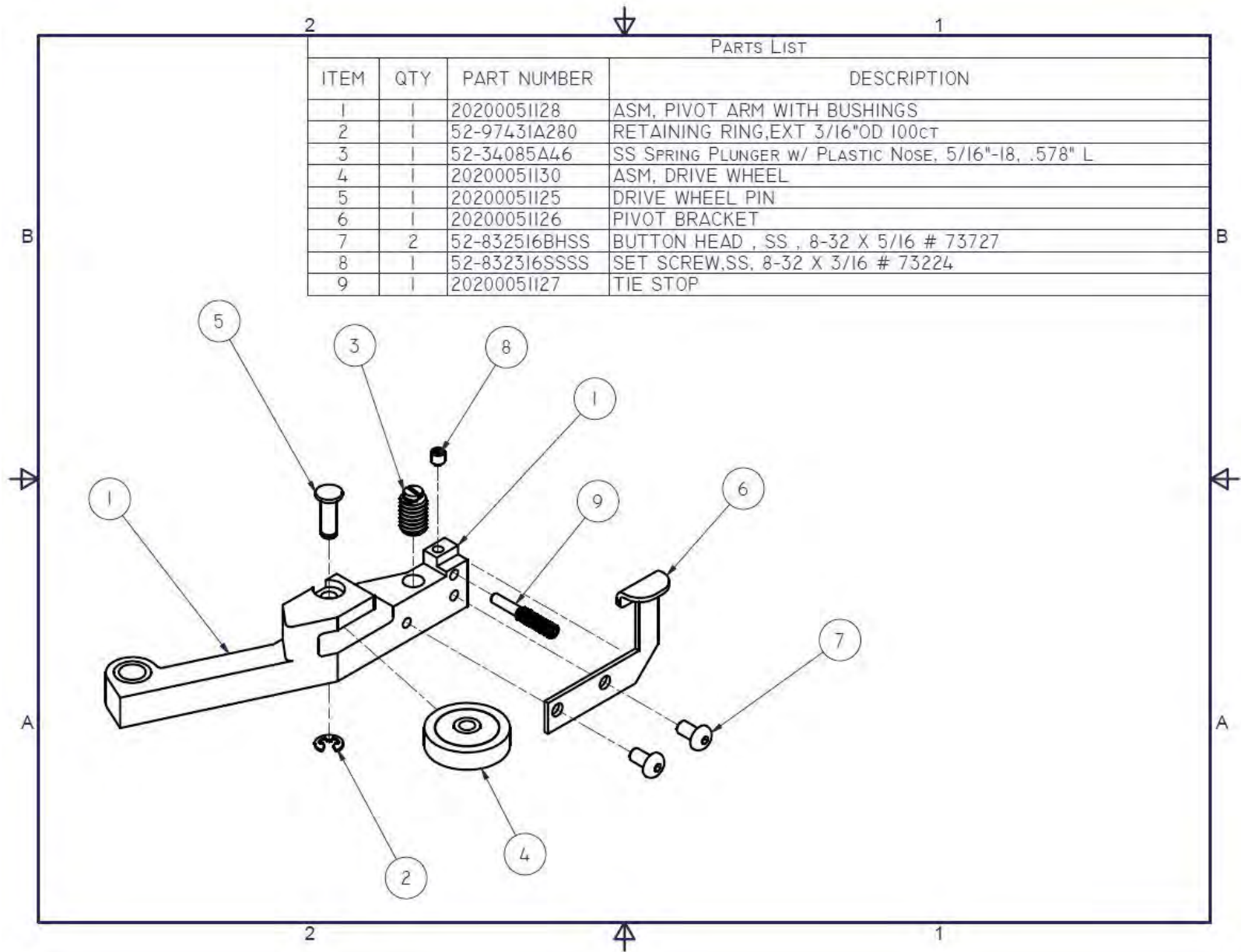

Figure 7.9 Drawing 20200051124 (All Models)

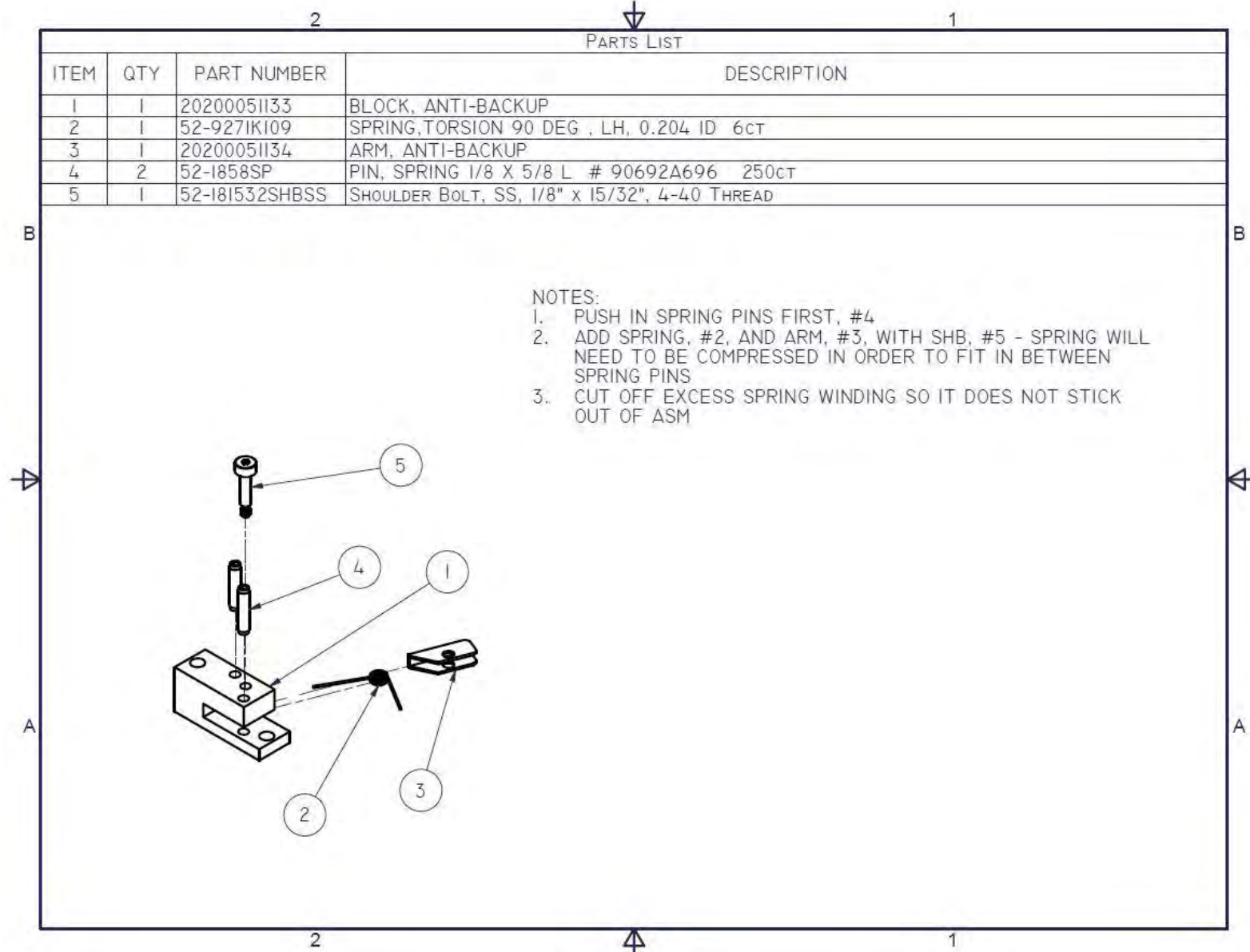

Figure 7.10 Drawing 20200051132 (All Models)

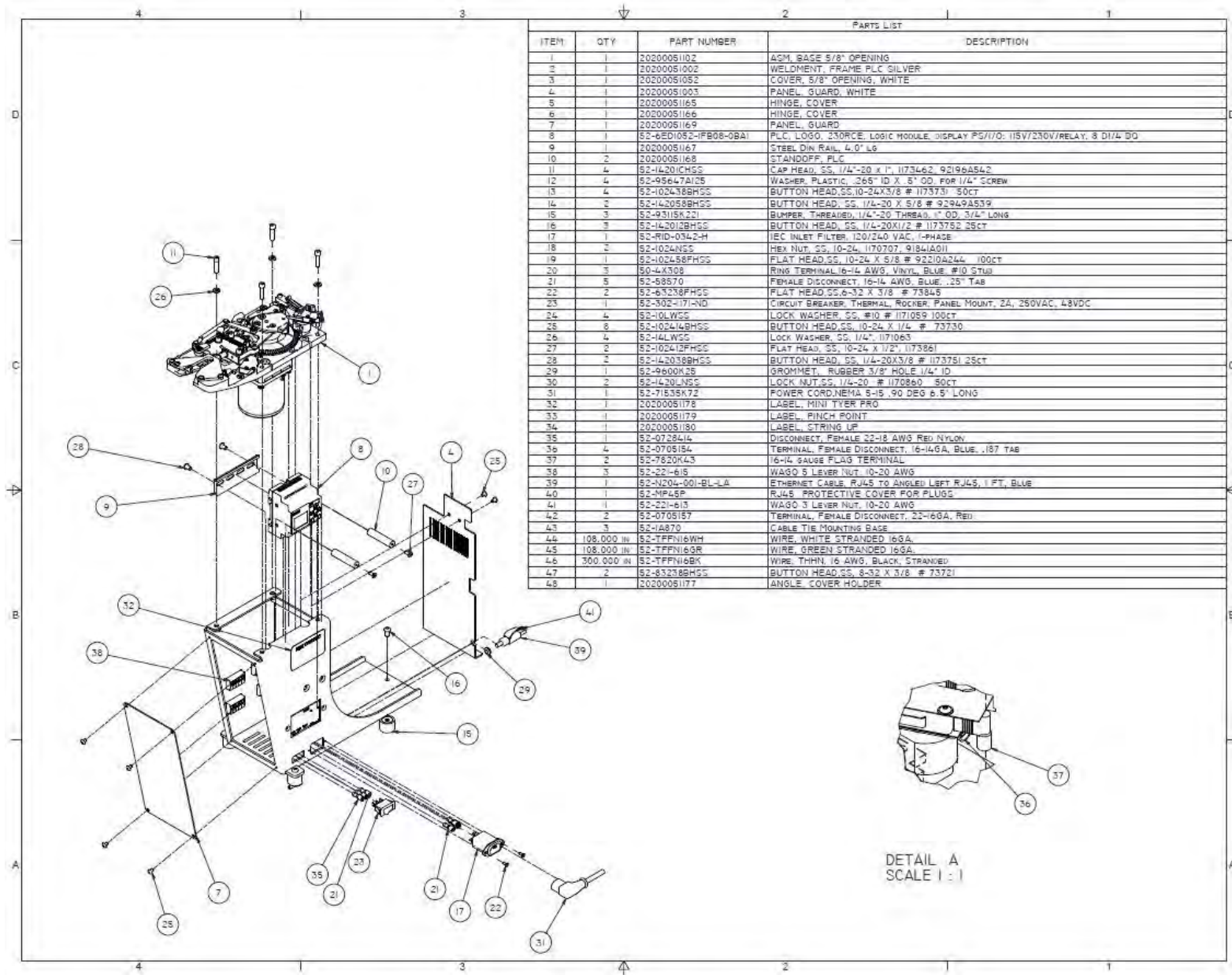

Figure 7.11 Drawing 20200051050 View 1 (5/8" Model, 120VAC)

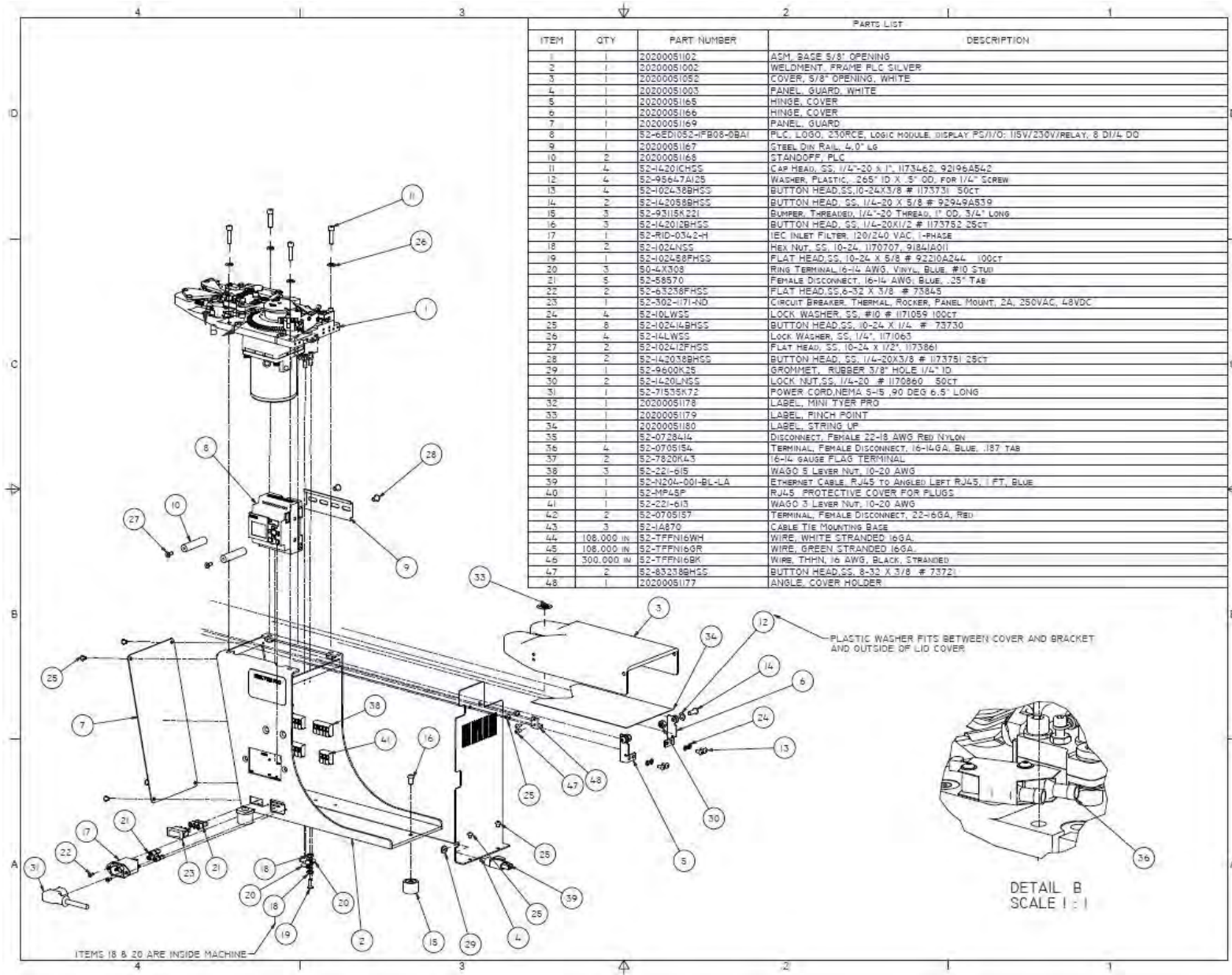

Figure 7.12 Drawing 20200051050 View 2 (5/8" Model, 120VAC)

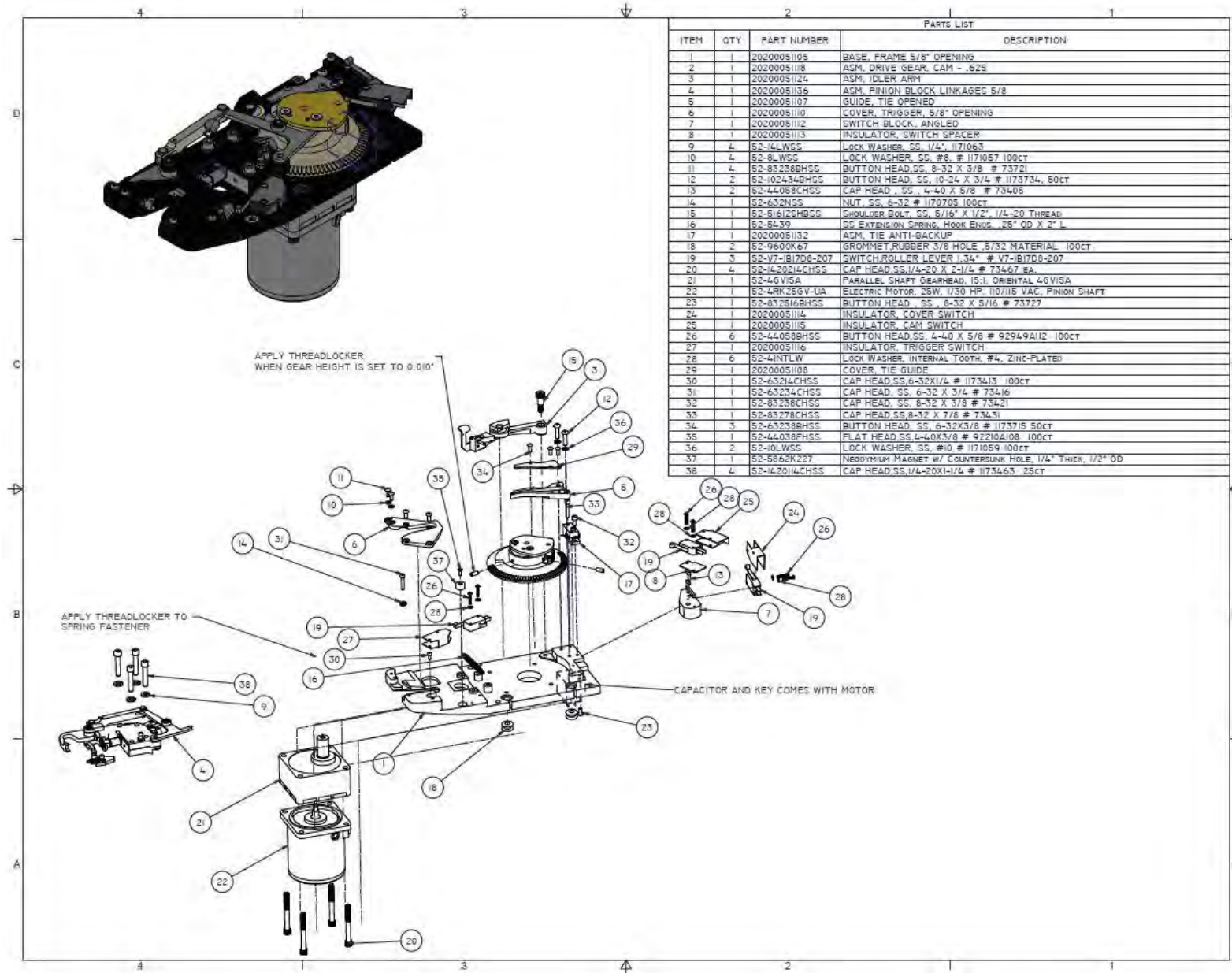

Figure 7.13 Drawing 20200051102 (5/8" Model, 120VAC)



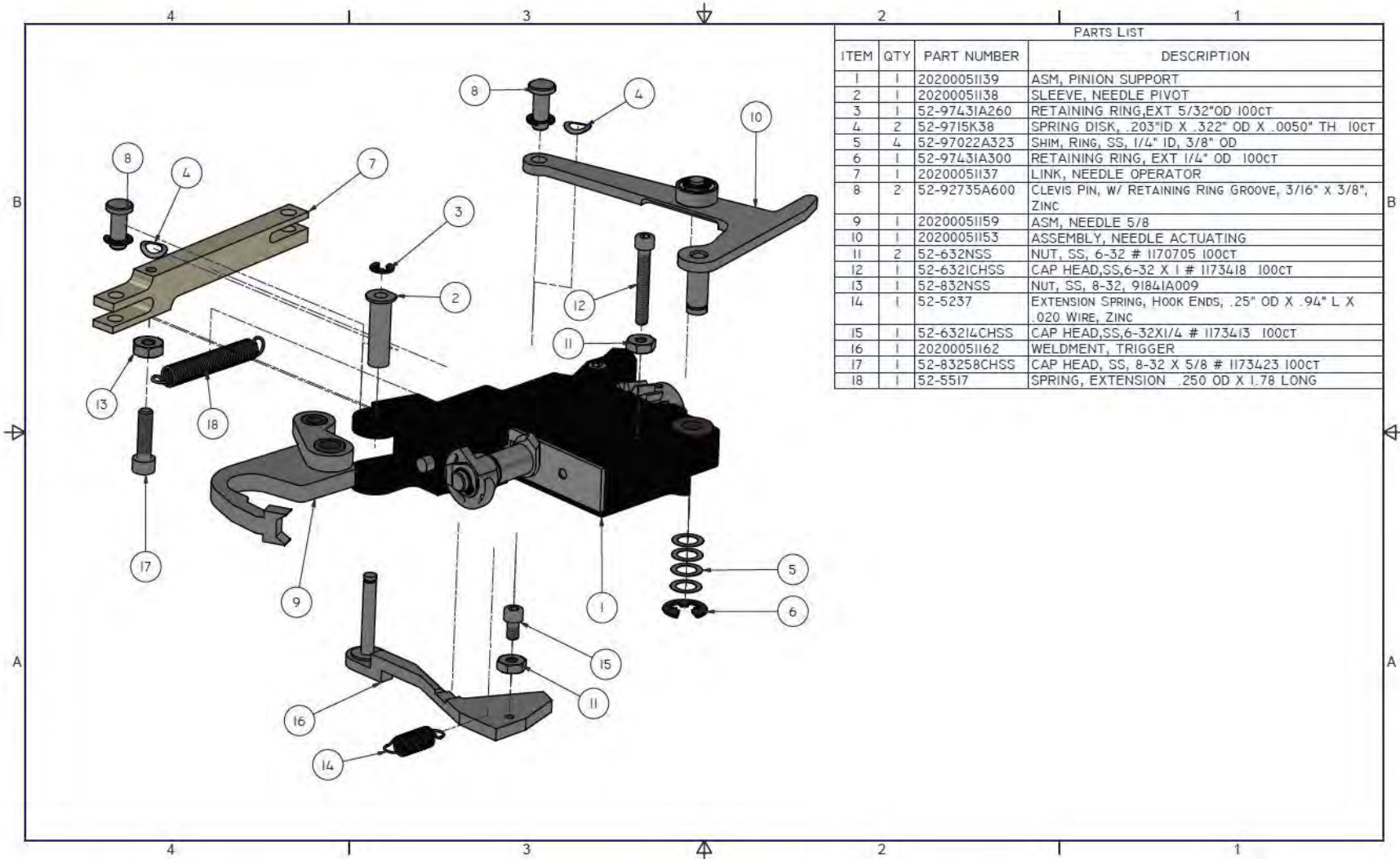

Figure 7.14 Drawing 20200051136 (5/8" Model)

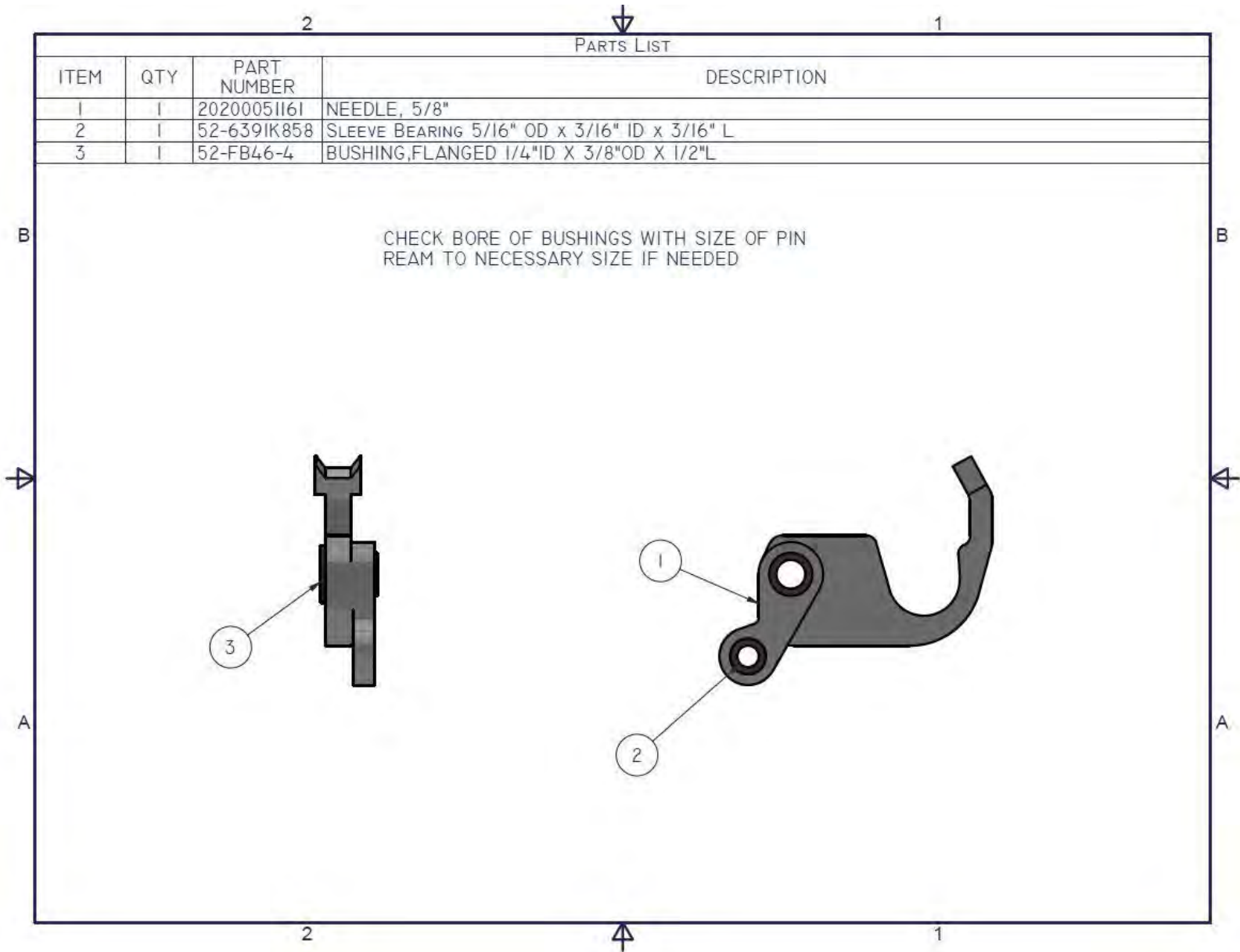

Figure 7.15 Drawing 20200051159 (5/8" Model)

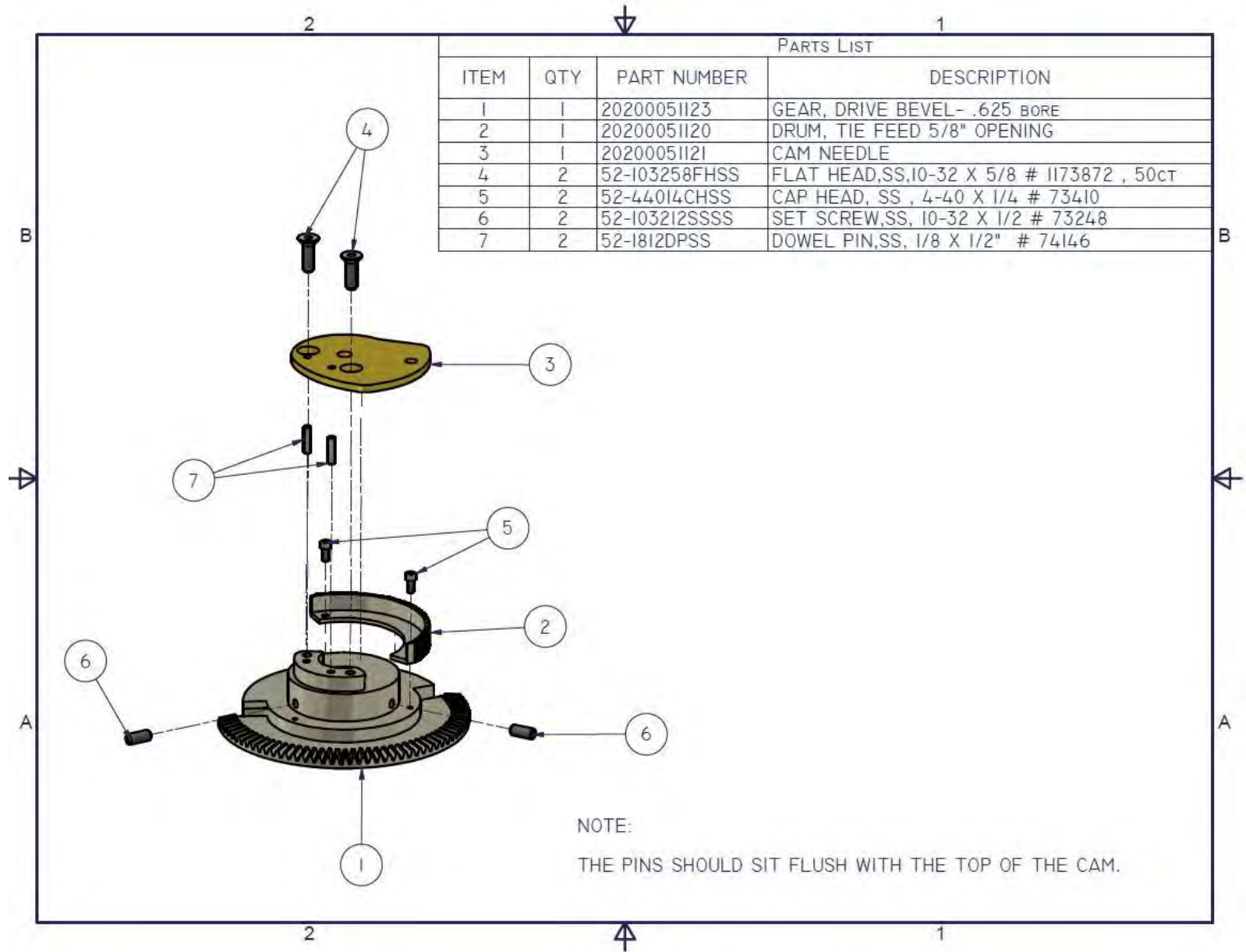

Figure 7.16 Drawing 20200051118 (5/8" Model)

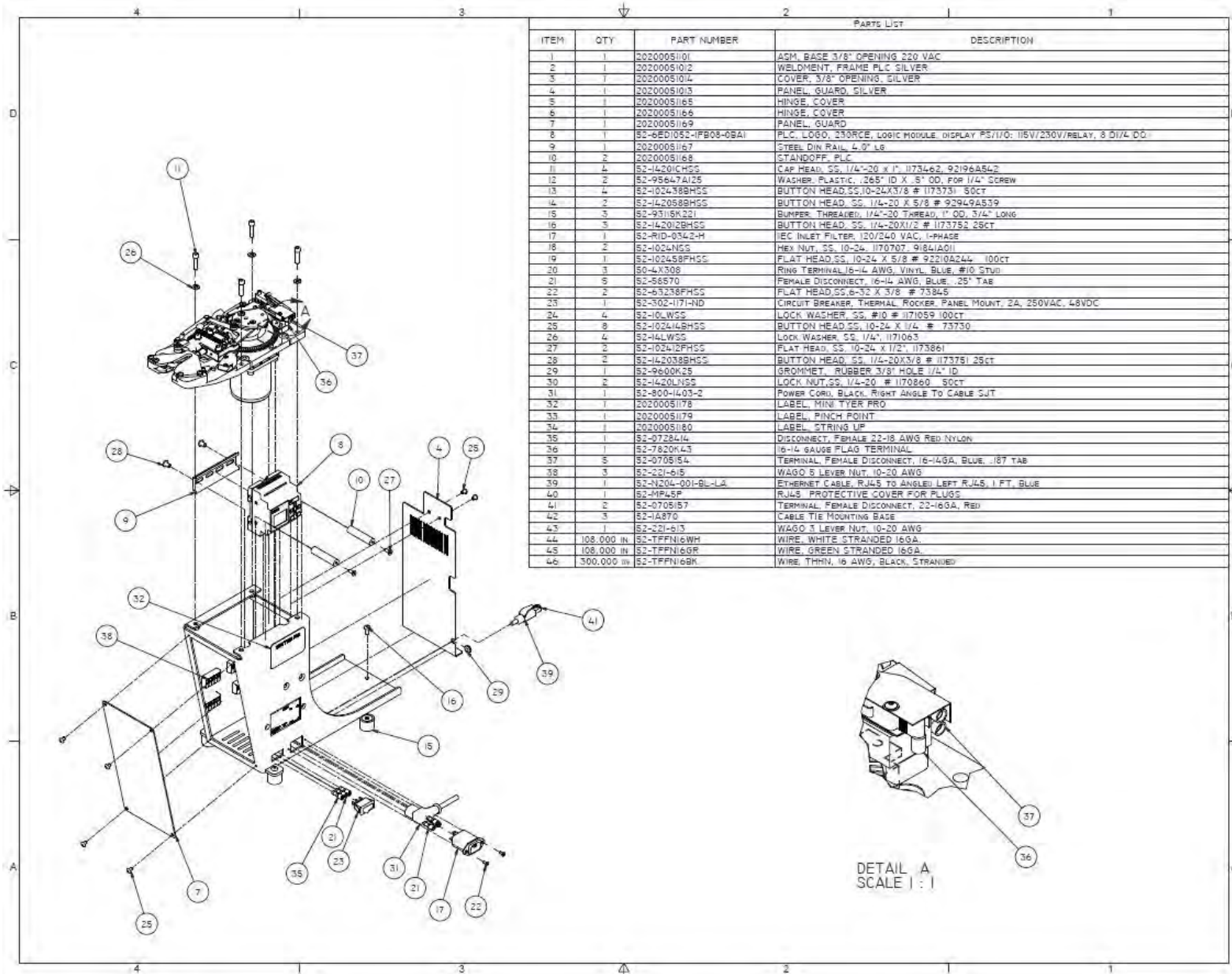

Figure 7.16 Drawing 20200051011 View 1 (3/8" Model, 240VAC)

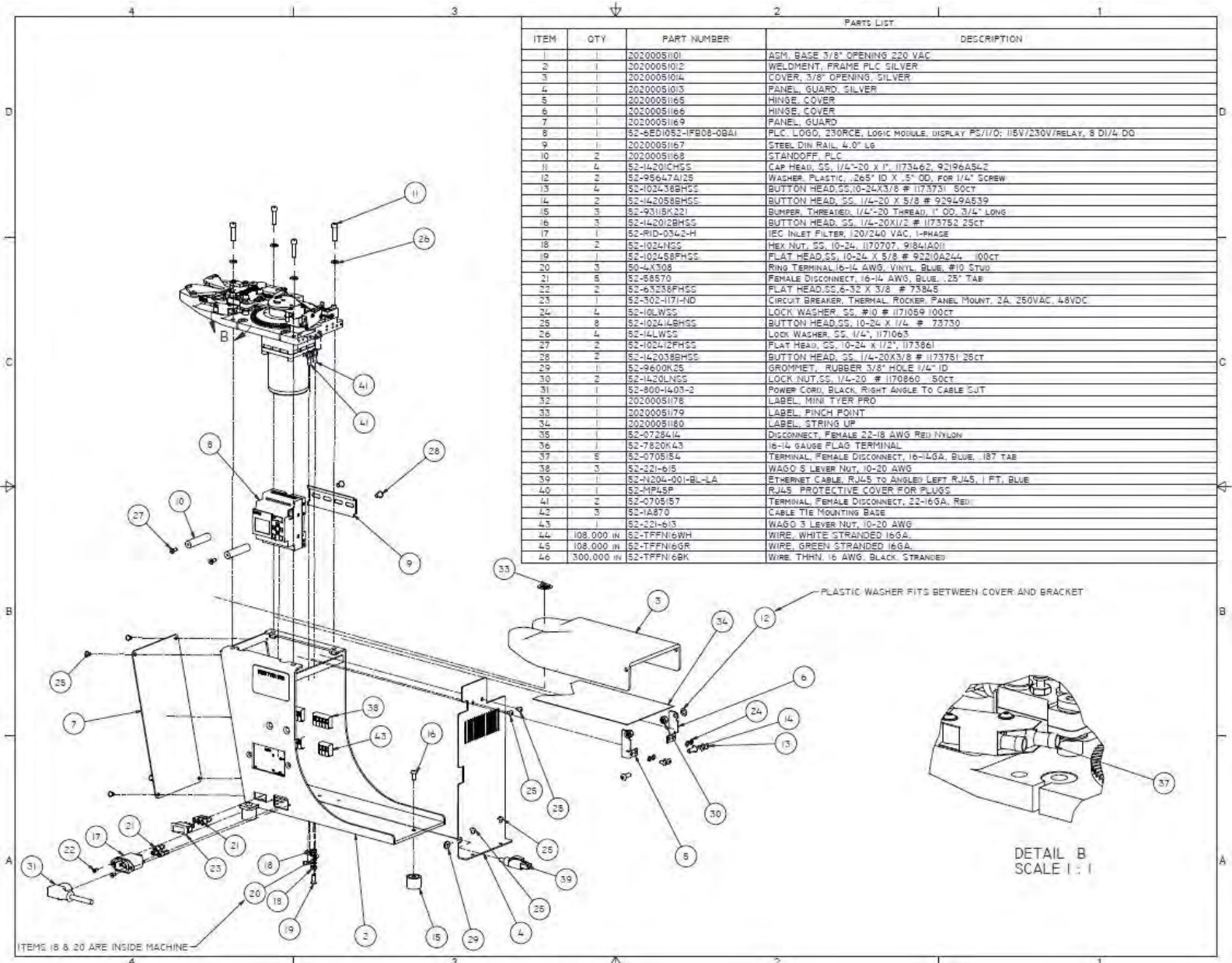

Figure 7.17 Drawing 20200051011 View 2 (3/8" Model, 240VAC)

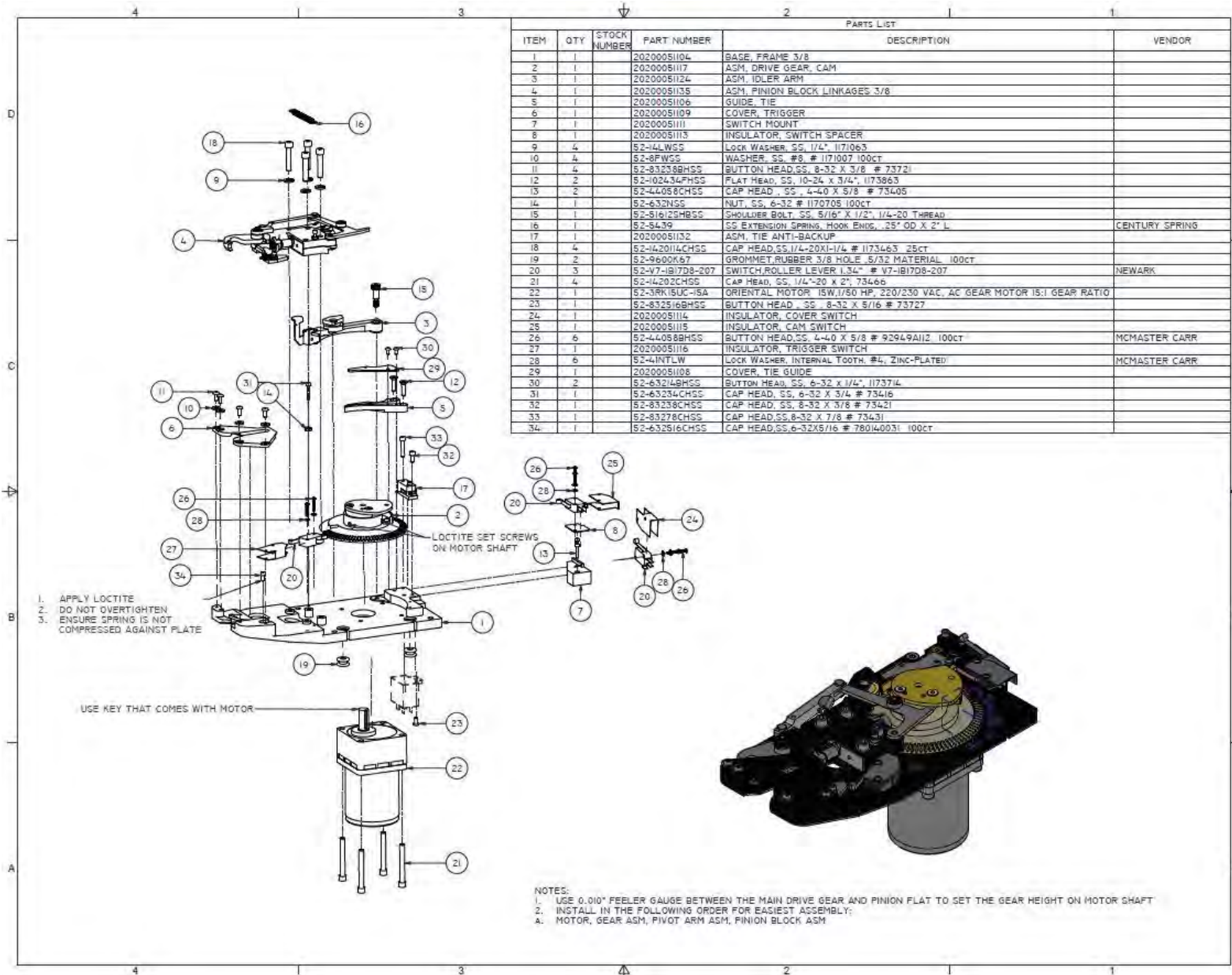

Figure 7.17 Drawing 20200051101 (3/8" Model, 240VAC)

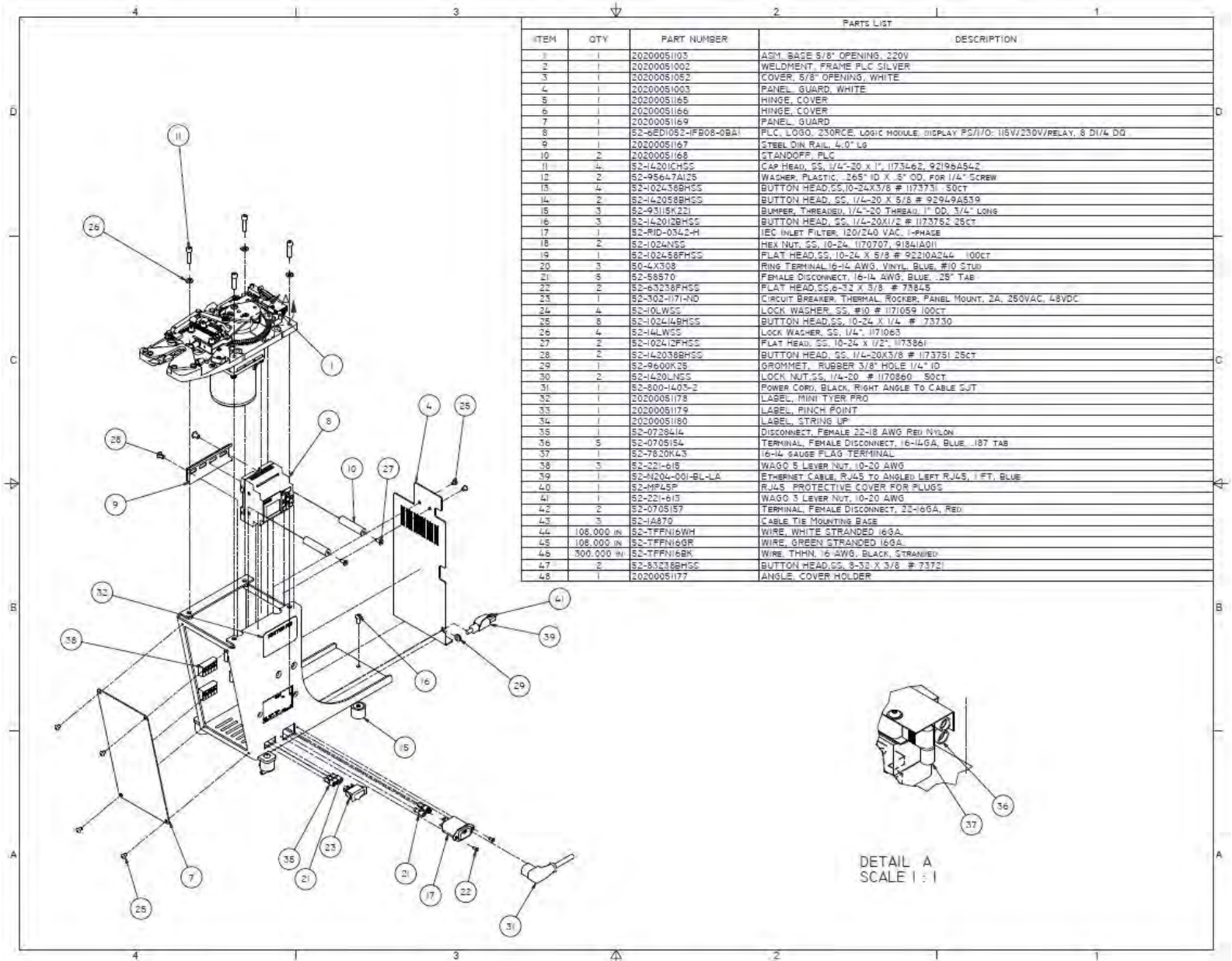

Figure 7.18 Drawing 20200051051 View 1 (5/8" Model, 240VAC)

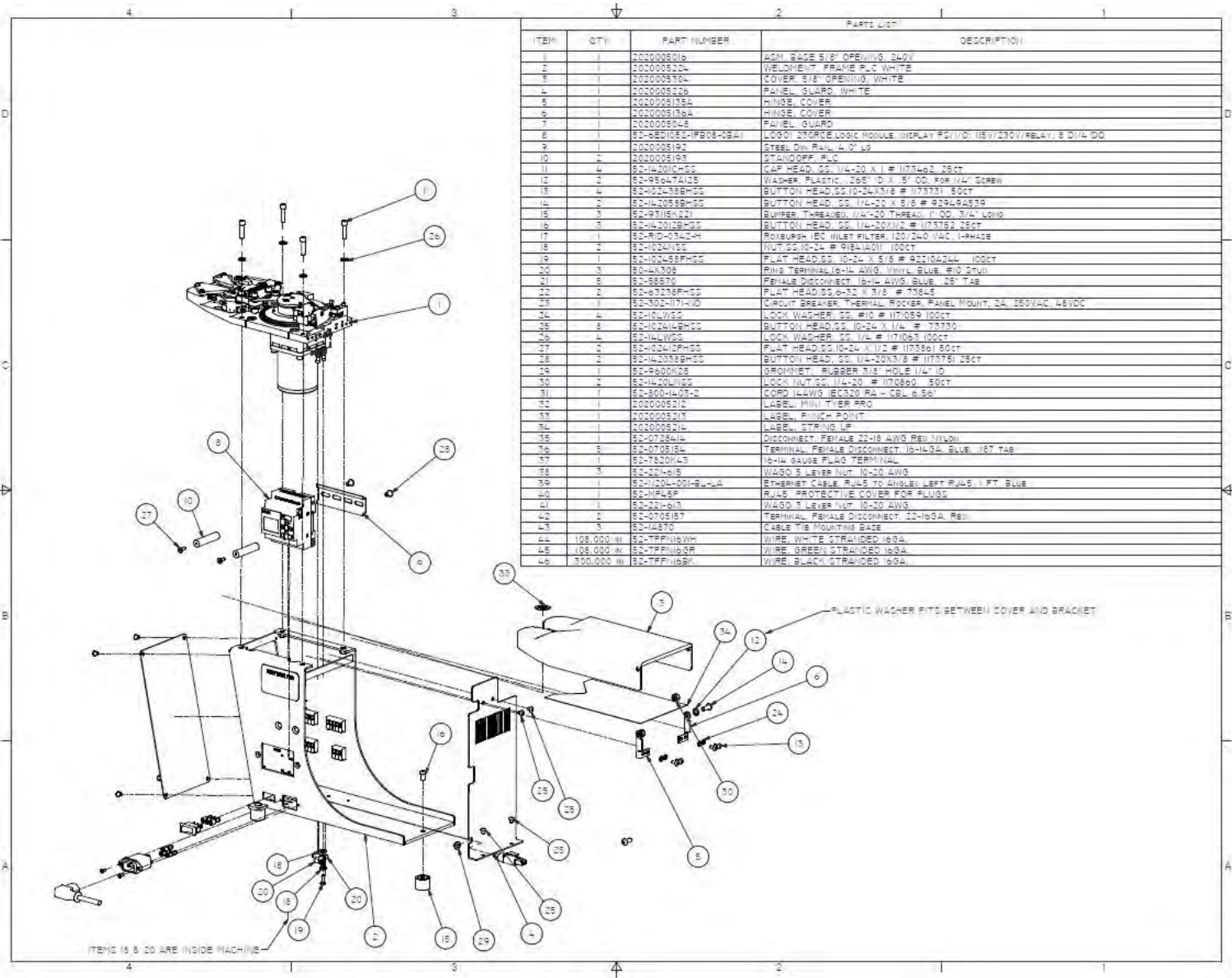

Figure 7.19 Drawing 20200051051 View 2 (5/8" Model, 240VAC)



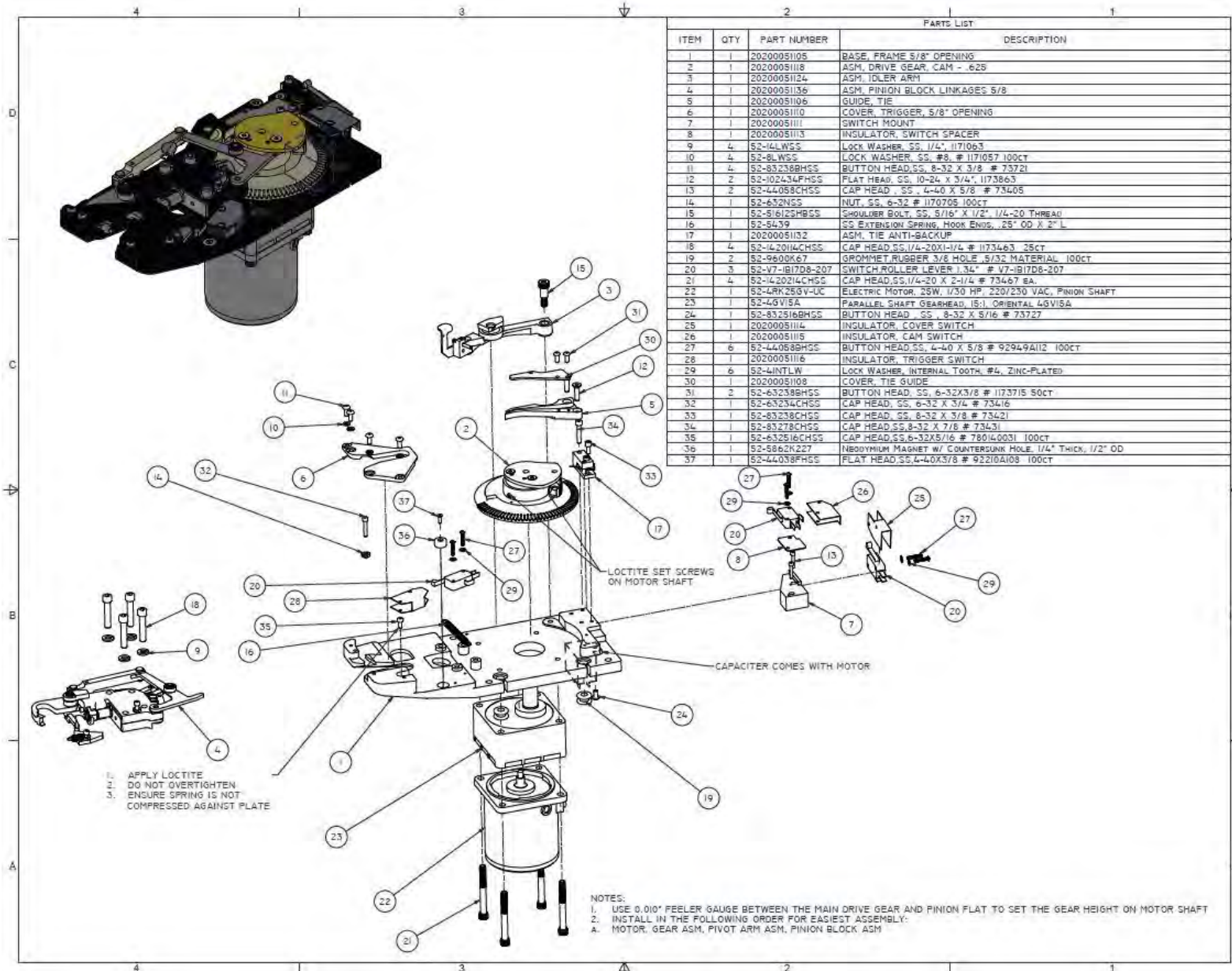

Figure 7.20 Drawing 20200051103 (5/8" Model, 240VAC)

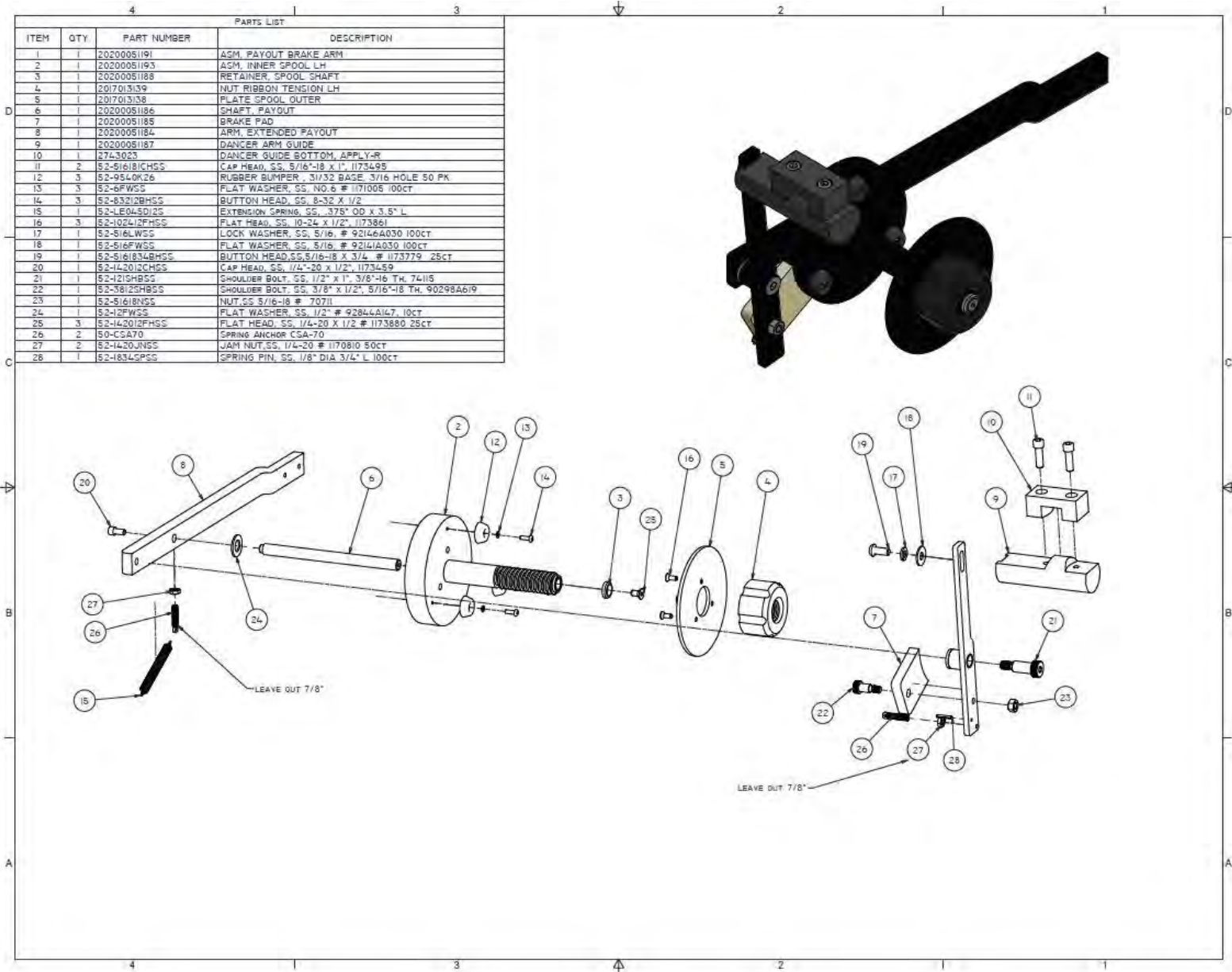

Figure 7.21 Drawing 20200051182 (Printer Model Only)

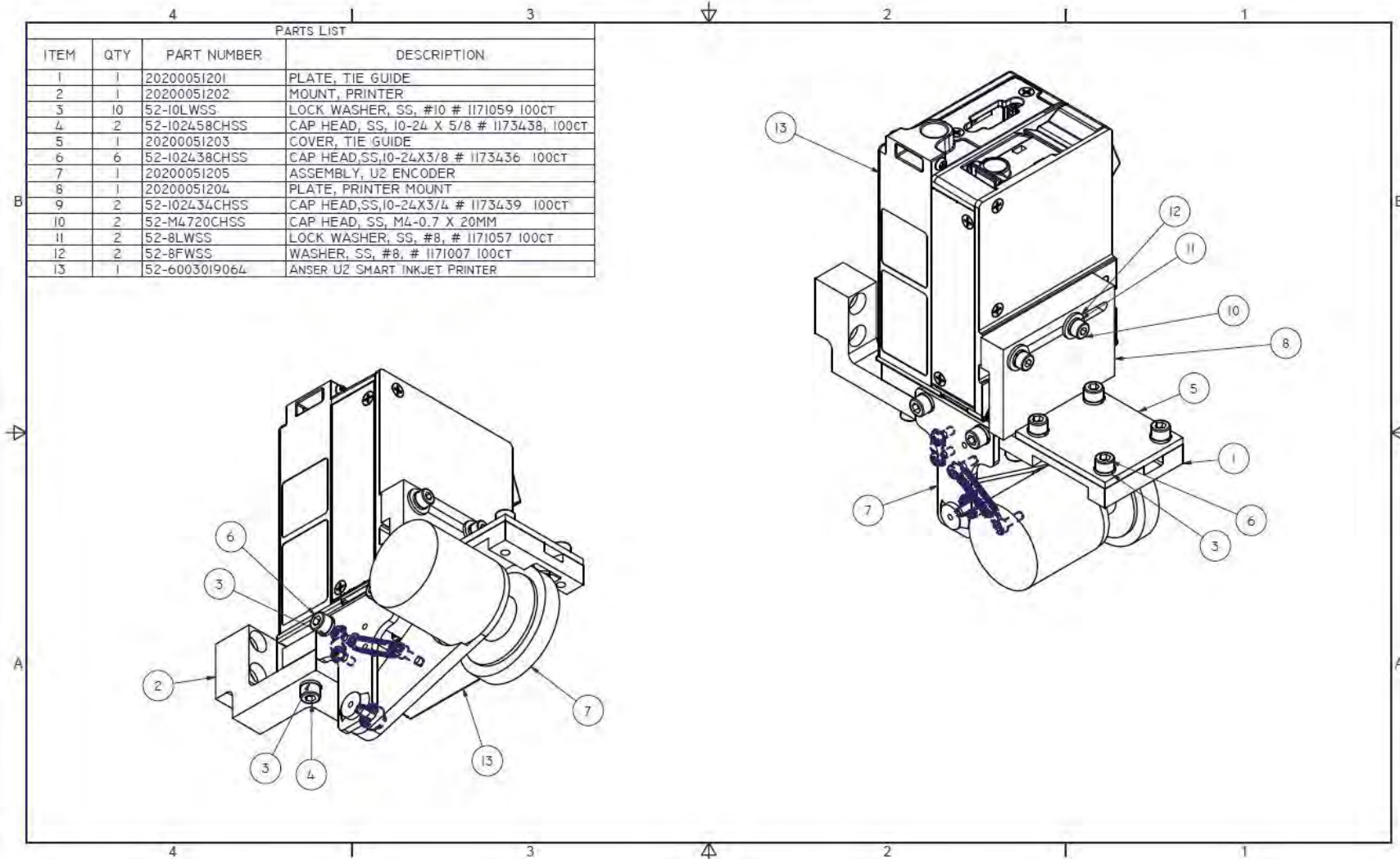

Figure 7.22 Drawing 20200051200 (Printer with Encoder Model Only)

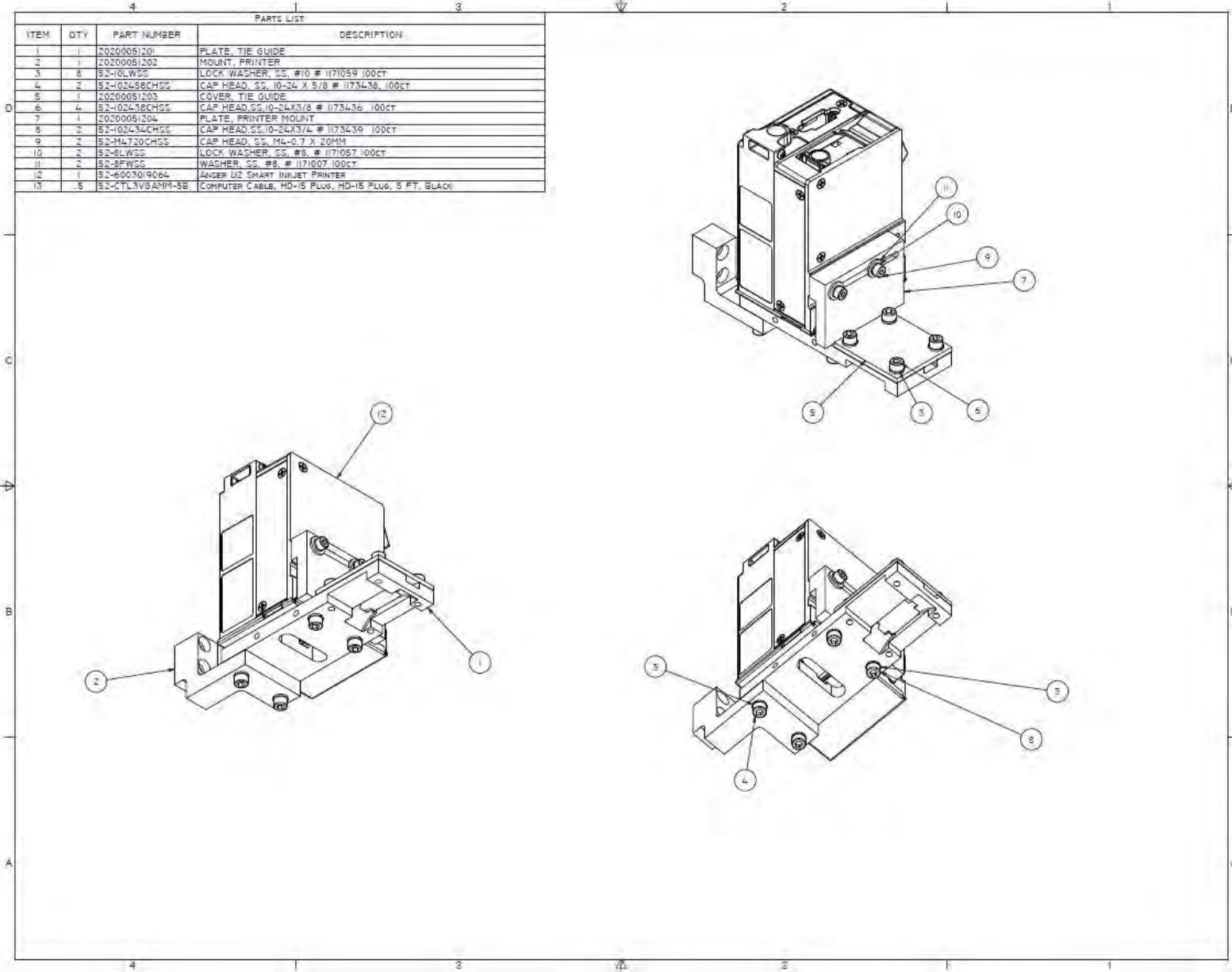

Figure 7.23 Drawing 20200051217 (Printer without Encoder Model Only)

# 8.0 Wiring Diagram

(Electrical Enclosure rated for 120/230 VAC)

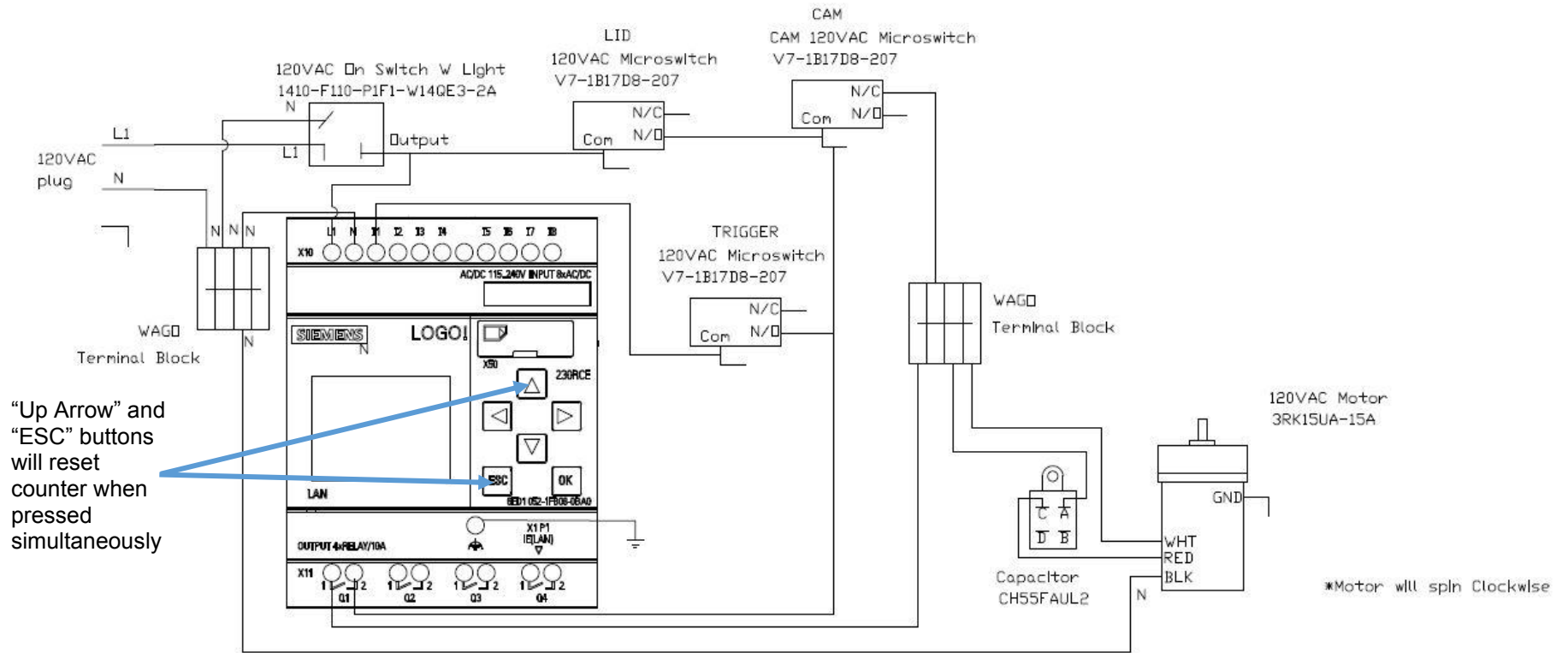

Figure 8.1 PLC Electrical Drawing

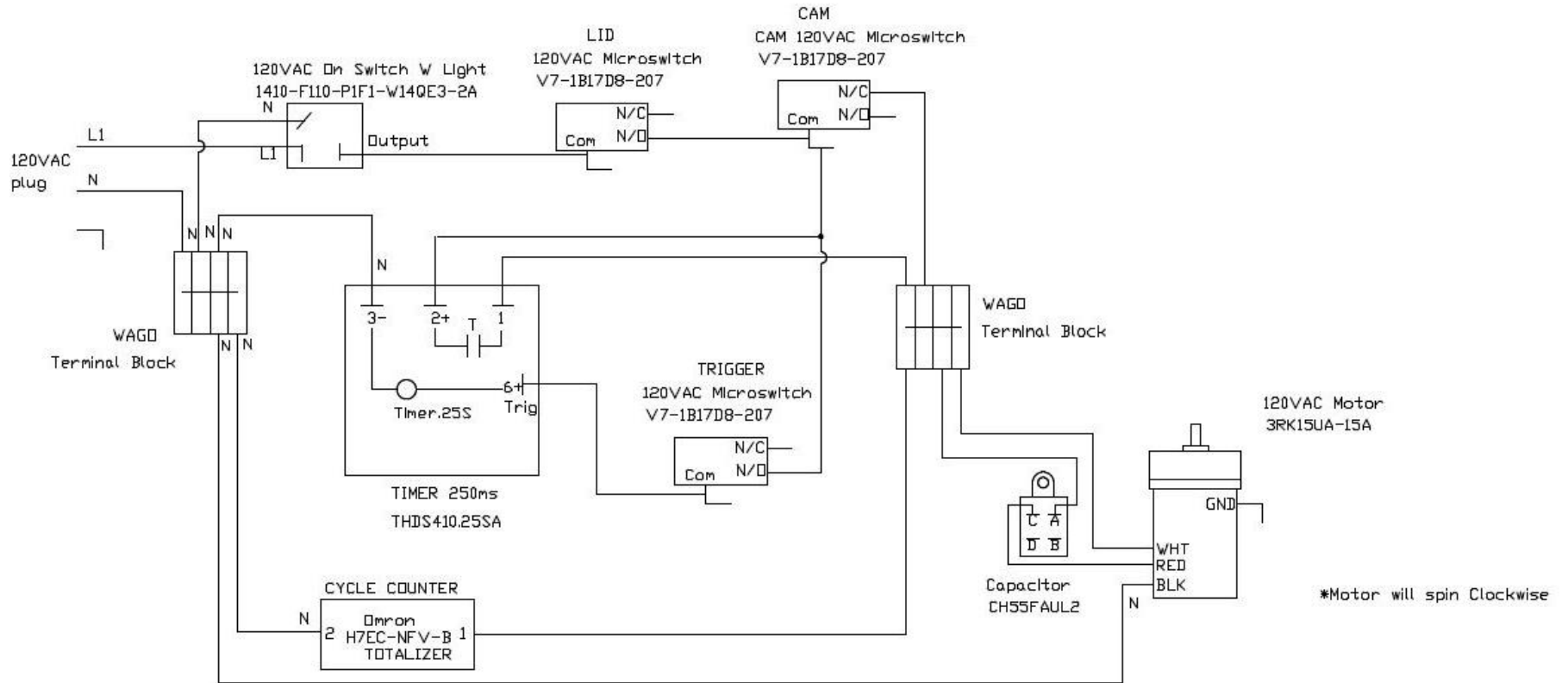

Figure 8.2 Solid State Timer/Counter Electrical Drawing

**Orientalmotor**

HM-9409

**OPERATING MANUAL**
**KII Series Reversible motor**  
 Single-phase 110/115 V, 220/230 V type

Thank you for purchasing an Oriental Motor product. This Operating Manual describes product handling procedures and safety precautions.

- Please read it thoroughly to ensure safe operation.
- Always keep the manual where it is readily available.

**Introduction**
**■ Before using the motor**

Only qualified and educated personnel should work with the product. Use the product correctly after thoroughly reading the section "Safety precautions." Should you require the inspection or repair of internal parts, contact the Oriental Motor office where you purchased the product. The product described in this manual has been designed and manufactured to be incorporated in general industrial equipment. Do not use for any other purpose. Oriental Motor Co., Ltd. is not responsible for any damage caused through failure to observe this warning.

**■ Standard and CE Marking**

- This product is recognized by UL under the UL and CSA standards. Also, it conforms to the China Compulsory Certification System (CCC System). The motor model name is the recognized product name.
- The motor is affixed the CE Marking under the Low Voltage Directive.

Refer to p.4 for details.

**■ Hazardous substances**

The products do not contain the substances exceeding the restriction values of RoHS Directive (2011/65/EU).

**Safety precautions**

The precautions described below are intended to prevent danger or injury to the user and other personnel through safe, correct use of the product. Use the product only after carefully reading and fully understanding these instructions.



Handling the product without observing the instructions that accompany a "Warning" symbol may result in serious injury or death.

- Do not use the product in explosive or corrosive environments, in the presence of flammable gases, or near combustibles. Doing so may result in fire, electric shock or injury.
- Only qualified and educated personnel should be allowed to perform installation, connection, operation and inspection/troubleshooting of the product. Handling by unqualified and uneducated personnel may result in fire, electric shock, injury or equipment damage.
- Do not transport, install the product, perform connections or inspections when the power is on. Always turn the power off before carrying out these operations. Failure to do so may result in electric shock.
- Turn off the power in the event the overheat protection device (thermal protector) is triggered. Failure to do so may result in injury or damage to equipment, since the motor will start abruptly when the overheat protection device (thermal protector) is automatically reset.
- The motor is Class I equipment. Install the motor so as to avoid contact with hands, or ground it to prevent the risk of electric shock.
- Keep the input power voltage within the specified range. Failure to do so may result in fire or electric shock.
- Securely connect the cables in accordance with the connection examples. Failure to do so may result in fire or electric shock.
- Do not forcibly bend, pull or pinch the read wire (cable). Doing so may result in fire and electric shock.
- Insulate the connection terminals of the supplied capacitor using the supplied capacitor cap. Failure to do so may result in electric shock.
- Turn off the power in the event of a power failure. Or the motor may suddenly start when the power is restored and may cause injury or damage to equipment.
- Do not touch the connection terminal of the capacitor immediately after the power is turned off (for a period of 30 seconds). The residual voltage may cause electric shock.
- Do not disassemble or modify the motor. This may cause electric shock or injury.

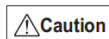

Handling the product without observing the instructions that accompany a "Caution" symbol may result in injury or property damage.

- Do not use the motor beyond its specifications. Doing so may result in electric shock, injury or damage to equipment.
- Do not touch the motor during operation or immediately after stopping. The surface is hot and may cause a skin burn(s).

- Do not lift the motor by holding the motor output shaft or motor lead wires. Doing so may result in injury.
- Keep the area around the motor free of combustible materials. Failure to do so may result in fire or a skin burn(s).
- Do not leave anything around the motor that would obstruct ventilation. Doing so may result in damage to equipment.
- Do not touch the rotating part (output shaft) while operating the motor. Doing so may result in injury.
- When an abnormality is noted, turn off the power immediately. Failure to do so may result in fire, electrical shock or injury.
- The motor surface temperature may exceed 70 °C (158 °F) even under normal operating conditions. If the operator is allowed to approach the running motor, attach a warning label as shown in the figure in a conspicuous position. Failure to do so may result in a skin burn(s).
- To dispose of the motor, disassemble it into parts and components as much as possible and dispose of individual parts/components as industrial waste.



Warning label

**Preparation**
**■ Checking the product**

Verify that the items listed below are included. Report any missing or damaged items to the branch or sales office from which you purchased the product.

- Motor ..... 1 unit
- This product comes with the motor and its dedicated gearhead pre-assembled.
- Capacitor ..... 1 piece
- Capacitor cap ..... 1 piece
- Hexagonal socket head screw set..... 1 set
- Hexagonal socket head screw, washer, spring washer 4 pieces each, parallel key 1 piece
- OPERATING MANUAL ..... 1 copy (this document)

**■ Checking the model name**

Check the model number against the number indicated on the product. Enter the gear ratio in the box (□) within the model name.

**● Lead wire type**

Model	Motor model	Gearhead model	Degree of protection
2RK6UA-□A	2RK6GV-UA	2GV□A	IP20
2RK6UC-□A	2RK6GV-UC		
3RK15UA-□A	3RK15GV-UA	3GV□A	
3RK15UC-□A	3RK15GV-UC		
4RK25UA-□A	4RK25GV-UA	4GV□A	
4RK25UC-□A	4RK25GV-UC		
5RK40UA-□A	5RK40GV-UA	5GV□A	
5RK40UC-□A	5RK40GV-UC		
5RK60UA-□A	5RK60GVH-UA	5GVH□A	
5RK60UC-□A	5RK60GVH-UC		
5RK90UA-□A	5RK90GVR-UA	5GVR□A	
5RK90UC-□A	5RK90GVR-UC		

**● Terminal Box Type**

Model	Motor model	Gearhead model	Degree of protection
4RK25UAT2-□A	4RK25GV-UAT2	4GV□A	IP40
4RK25UCT2-□A	4RK25GV-UCT2		
5RK40UAT2-□A	5RK40GV-UAT2	5GV□A	
5RK40UCT2-□A	5RK40GV-UCT2		
5RK60UAT2-□A	5RK60GVH-UAT2	5GVH□A	IP20
5RK60UCT2-□A	5RK60GVH-UCT2		
5RK90UAT2-□A	5RK90GVR-UAT2	5GVR□A	
5RK90UCT2-□A	5RK90GVR-UCT2		

## Installation

### Location for installation

Install it in a well-ventilated location that provides easy access for inspection.

- Inside an enclosure that is installed indoors (provide vent holes)
- Operating ambient temperature -10 to +40 °C (+14 to +104 °F) (non-freezing)
- Operating ambient humidity 85% or less (non-condensing)
- Area that is free from an explosive atmosphere or toxic gas (such as sulfuric gas) or liquid
- Area not exposed to direct sun
- Area free of excessive amount dust, iron particles or the like
- Area not subject to splashing water (storms, water droplets), oil (oil droplets) or other liquids
- Area free of excessive salt
- Area not subject to continuous vibration or excessive shocks
- Area free of excessive electromagnetic noise (from welders, power machinery, etc.)
- Area free of radioactive materials, magnetic fields or vacuum
- 1000 m (3300 ft.) or less above sea level

**Note** On rare occasions, grease may ooze out from the gearhead. If there is a concern over possible environmental damage resulting from the leakage of grease, provide an oil tray or similar oil catching mechanism in order not to cause a secondary damage. Oil leakage may lead to problems in the customer's equipment or products.

### How to install the motor

Secure the motor with hexagonal socket head screws (supplied) through the four mounting holes provided. Do not leave a gap between the motor and mounting plate.

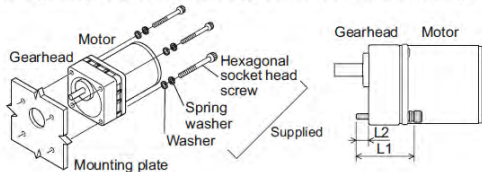

### Hexagonal socket head screw set (supplied)

Model	Gear ratio	Hexagonal socket head screw Material: Stainless steel			Tightening torque
		Screw size	L1 [mm (in.)]	L2 [mm (in.)]	
2RK6	5 to 25	No.8-32UNC	50.8 (2)	8 (0.31)	1.4 N·m (12 lb-in)
	30 to 120		57.2 (2.25)	10 (0.39)	
	150 to 360		63.5 (2.5)	12 (0.47)	
3RK15	5 to 25	1/4-20UNC	57.2 (2.25)	9 (0.35)	5.0 N·m (44 lb-in)
	30 to 120		63.5 (2.5)	10 (0.39)	
	150 to 360		69.9 (2.75)	12 (0.47)	
4RK25	5 to 25	1/4-20UNC	63.5 (2.5)	12 (0.47)	5.0 N·m (44 lb-in)
	30 to 120		69.9 (2.75)	14 (0.55)	
	150 to 360		76.2 (3)	15 (0.59)	
5RK40 5RK60	5 to 18	5/16-18UNC	69.9 (2.75)	14 (0.55)	12.0 N·m (106 lb-in)
	25 to 100		82.6 (3.25)	13 (0.51)	
	120 to 300		88.9 (3.5)	14 (0.55)	
5RK90	5 to 15	5/16-18UNC	69.9 (2.75)	14 (0.55)	12.0 N·m (106 lb-in)
	18 to 36		82.6 (3.25)	13 (0.51)	
	50 to 180		95.3 (3.75)	14 (0.55)	

### Removing/Installing the gearhead

See the following steps to replace the gearhead or to change the outlet position of the lead wires and the position of the terminal box.

#### Removing the gearhead from the motor

Remove the hexagonal socket head screws (2 pcs.) assembling the motor and gearhead and detach the motor from the gearhead.

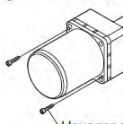

Gearhead model	Screw size	Tightening torque
2GV□A 3GV□A 4GV□A	M2.6	0.4 N·m (3.5 lb-in)
5GV□A 5GVH□A 5GVR□A	M3	0.6 N·m (5.3 lb-in)

### Installing the gearhead to the motor

1. Keep the pilot sections of the motor and gearhead in parallel, and assemble the gearhead with the motor while slowly rotating it clockwise/counterclockwise.  
At this time, note so that the pinion of the motor output shaft does not hit the side panel or gears of the gearhead strongly.
2. Check no gaps remain between the motor and gearhead, and tighten them with hexagonal socket head screws (2 parts).

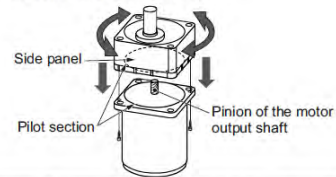

Assemble the gearhead to the motor in a condition where the motor output shaft is in an upward direction.

- Note**
- Do not forcibly assemble the motor and gearhead. Also, do not let metal objects or other foreign matters enter the gearhead. The pinion of the motor output shaft or gear may be damaged, resulting in noise or shorter service life.
  - Do not allow dust to attach to the pilot sections of the motor and gearhead. Also, assemble the motor and gearhead carefully by not pinching the O-ring at the motor pilot section. If the O-ring is crushed or severed, grease may leak from the gearhead.
  - The hexagonal socket head screws assembling the motor and gearhead are used to attach the motor and gearhead temporarily. When installing the motor/gearhead assembly, be sure to use the supplied hexagonal socket head screws.

### Motor with cooling fan

When installing a motor with cooling fan onto a device, leave 10 mm (0.39 in.) or more behind the fan cover or open a ventilation hole so that the cooling inlet on the back of the motor cover is not blocked.

### Mounting the capacitor

Mount the capacitor securely by using No.8-32UNC or M4 screws (not provided).

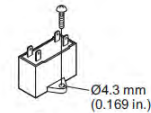

- Note**
- Do not let the screw fastening torque exceed 1 N·m (8.8 lb-in) to prevent damage to the mounting foot.
  - Mount capacitor at least 10 cm (3.94 in.) away from the motor. If it is located closer, the life of the capacitor will be shortened.

### Installing a load

The gearhead shaft is provided with a key slot for connecting the transmission parts. When connecting the transmission parts, ensure that the shaft and parts have a clearance fit, and always fix the parallel key to the output shaft with a screw to prevent the parts from rattling or spinning.

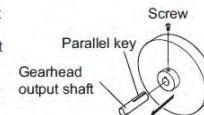

- Note** Do not apply excessive force onto the output shaft of the gearhead using a hammer or other tools. Doing so may cause damage to the output shaft or bearings.

### When using the output shaft end tapped hole of a gearhead

Use a tapped hole provided at the end of the output shaft as an auxiliary means for preventing the transfer mechanism from disengaging. (2GV□A, 3GV□A type have no output shaft end tapped hole.)

Gearhead model	Output shaft end tapped hole
4GV□A	No.10-24 UNC, Effective depth 10 mm (0.39 in.)
5GV□A 5GVH□A 5GVR□A	No.12-24 UNC, Effective depth 12 mm (0.47 in.)

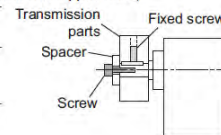



### Connection and operation

- Insulate all the wire connections, such as the connection between the motor and the capacitor connection.
- Ground the motor using a Protective Earth Terminal.

**Note** Make sure that the motor case temperature does not exceed 90 °C (194 °F) when operating the motor. Operation exceeding case temperature 90 °C (194 °F) may significantly deteriorate the coils and ball bearings of the motor and shorten the motor's life span. Motor case temperature can be measured by fixing a thermometer on the motor surface. It can also be measured using thermo tape or a thermocouple.

### Wiring diagram

Check the output power and gear ratio of the motor before connecting.  
Wiring diagram No.

Motor model	Gear ratio	Wiring diagram	Gear ratio	Wiring diagram
2RK6 3RK15 4RK25	5 to 25, 150 to 360	Lead wire type: ①	30 to 120	Lead wire type: ②
5RK40 5RK60	5 to 18, 120 to 300	Terminal box type: ③	25 to 100	Terminal box type: ④
5RK90	5 to 15, 75 to 180		18 to 60	

Wiring diagram

⊕ Protective Earth Terminal

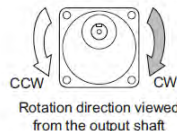
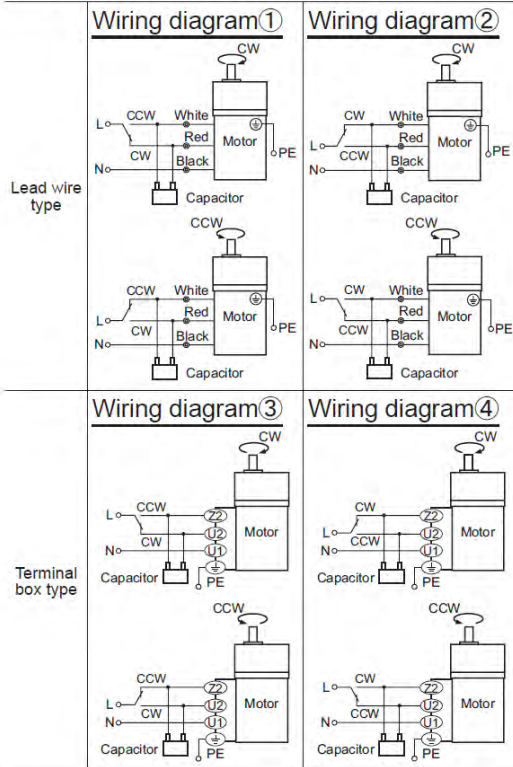

The direction of rotation is as viewed from the side of the output shaft. The rotation in the clockwise direction represents "CW" and the rotation in the counterclockwise direction represents "CCW." The rotation direction of the output shaft varies depending on the gear ratio of the gearhead.

### Contact protection

In order to protect the relay contacts, a CR circuit must be connected. Optional surge absorber is available (sold separately).  
Model: EPCR1201-2

### Capacitor connection

The capacitor internal wiring as follows: Capacitor terminals are internally electrically connected in twos, A-B and C-D for easy connection.

For easy to install terminals use 187 series FASTON terminals (TE Connectivity).

Use the supplied capacitor cap to insulate the capacitor terminal connection.

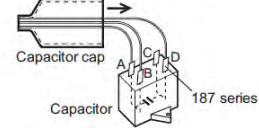

**Note** For lead wire connection, use one lead wire for each individual terminal.

### Lead wire type

#### Connecting Protective Earth Terminal

Be sure to ground the motor using the Protective Earth Terminal (⊕) on the motor.

Applicable crimp terminal:  
Insulated round crimp terminal  
Terminal screw size: M4  
Tightening torque:  
1.0 to 1.3 N·m (8.8 to 11.5 lb-in)  
Applicable minimum lead wire size:  
AWG18 (0.75mm<sup>2</sup>) or thicker

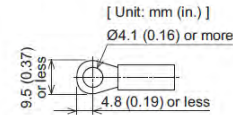

**Note** Do not use screws other than the Protective Earth Terminal screw attached on the product.

### Terminal Box Type

#### Connection method to a terminal box

##### Connection procedure

1. Loosen the terminal box cover mounting screws, and remove the terminal box cover from the terminal box.
2. Insert the cable through the cable gland, and connect the lead wires to the terminal block.  
Connect the grounding lead wire to the Protective Earth Terminal.
3. Install the terminal box cover on the terminal box.

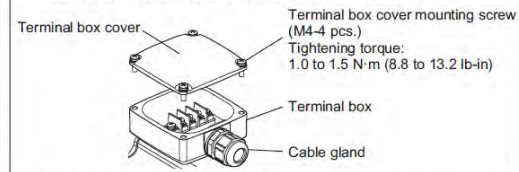

#### Insert the cable through the cable gland.

When inserting the cable through the cable gland, loosen the tightening nut. After connecting to the terminal block, turn the tightening nut to secure the cable.

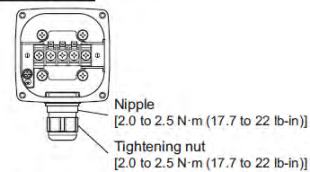

[ ] indicates the value of the tightening torque.

#### Connection method to a terminal block

- When connecting to the terminal block, use the following crimp terminal.

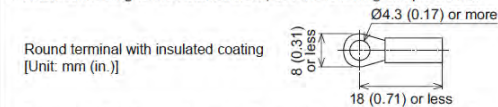

- To ensure safety, be sure to ground the motor using the Protective Earth Terminal (⊕) inside the terminal box.

#### Layout of terminals

- Z2, U2 and U1 are indicated on the side face of the terminal block.

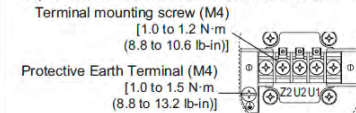

[ ] indicates the value of the tightening torque.

- Use a cable of the following specifications.  
Applicable cable diameter: Ø7 to Ø13 mm (Ø0.28 to Ø0.51 in.)  
Applicable lead wire: AWG18 (0.75 mm<sup>2</sup>) or thicker  
Connection cables are available as accessories. Refer to the product catalog for details.
- Although the O-ring that is set to the matching surface of the terminal box cover is a structure not to fall off easily, install it in the groove portion of the terminal box cover securely if it fell off.

**Note**

- To make shielding function fully effective, use a cable of an appropriate diameter and observe the specified tightening torque of screws.
- Secure the cable drawn from the motor terminal box so that it does not receive stress.

### ● Changing the cable outlet position

The cable outlet position can be changed to the left or right 90-degree direction, or the 180-degree direction by changing the mounting direction of the terminal box. When changing the mounting direction of the terminal box, specify the cable outlet position based on the equipment to be installed.

#### Change procedure

1. Loosen the terminal box cover mounting screws, and remove the terminal box cover from the terminal box.
2. Loosen the terminal box mounting screws, and remove the terminal box from the motor case.
 

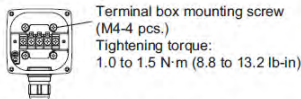
3. Change the cable outlet position of the terminal box from the mounting position at the time of shipment by turning the terminal box itself to the left or right 90-degree direction, or the 180-degree direction.

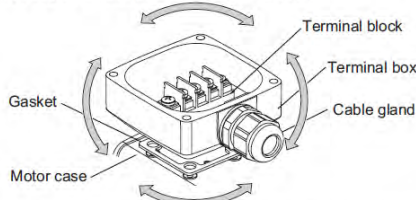

**Note**

- Be sure to use the gasket which has been put in the product at the time of shipment.
- Assemble not to enter any foreign object between the terminal box and motor case.

### Time rating

Reversible motors have a 30 minutes rating. "30 min" is indicated on the nameplate.

### Overheat protection for locked condition

This motor is equipped with one of the two features listed below to prevent the motor from burning out as a result of abnormal heating which may be caused by misapplication.

#### ■ Thermally protected motors

"TP" is marked on the motor nameplate. This motor contains a built-in automatic return type thermal protector in the motor windings. If the motor internal temperature exceeds the specified value, the thermal protector is activated and the motor is stopped. Always turn the power off before performing inspections.

Operating temperature of thermal protector:  
Open (motor standstill) .....130±5 °C (266±9 °F)  
Close (resuming operation) .....85±20 °C (185±36 °F)

#### ■ Impedance protection

"ZP" is stamped on the motor nameplate. The motor has higher coil impedance. When the motor goes into locked rotor condition due to a malfunction, coil impedance rises, suppressing input power to the motor and protecting the motor coil from burnout.

### Troubleshooting

When the motor cannot be operated correctly, refer to the contents provided in this section and take appropriate action. If the problem persists, contact your nearest office.

Phenomena	Check items
Motor does not rotate.	<ul style="list-style-type: none"> <li>• Check the power supply voltage.</li> <li>• Connect the power supply and the motor correctly.</li> <li>• Connect the supplied capacitor correctly.</li> </ul>
Motor sometimes rotates and stops.	<ul style="list-style-type: none"> <li>• If terminal blocks or crimp terminals are used, check them for poor connection.</li> <li>• Keep the load at or below the allowable value.</li> </ul>
The motor rotates in the direction opposite to the specified direction.	<ul style="list-style-type: none"> <li>• Connect the supplied capacitor correctly.</li> <li>• The connection varies depending on the gear ratio of the gearhead.</li> <li>• The rotation direction is as viewed from the output shaft end. Check the reference direction.</li> </ul>

Phenomena	Check items
Motor temperature abnormally high [Motor case temperature exceeds 90 °C (194 °F)]	<ul style="list-style-type: none"> <li>• Check the power supply voltage.</li> <li>• With a single-phase motor, connect the supplied capacitor correctly.</li> <li>• Review the ventilation condition.</li> </ul>
Noisy operation	<ul style="list-style-type: none"> <li>• Assemble the motor and gearhead correctly.</li> <li>• Assemble a gearhead of the same pinion type as the motor.</li> </ul>

### Standard and CE Marking

- This product is recognized by UL under the UL and CSA standards. Also, it conforms to the China Compulsory Certification System (CCC System). The motor model name is the recognized product name.
- The motor is affixed the CE Marking under the Low Voltage Directive.

#### ■ UL Standards, CSA Standards, CCC System

Applicable standards	Certification Body / File No.
UL 1004-1, UL 1004-2, UL 1004-3	UL /
CSA C22.2 No.100, CSA C22.2 No.77	UL File No.E64197, E64199
GB 12350	CQC

- Thermal Class: 130 (B)

#### ■ Low Voltage Directive

- Applicable standards  
EN 60034-1, EN 60034-5, EN 60664-1

Momentary excess torque based on EN 60034-1

Model	Momentary excess torque	Momentary excess torque represents a maximum torque that can maintain the operation for 15 seconds without stalling or abrupt speed change even if the torque is increased gently while operating at rated voltage and rated frequency.
2RK6, 3RK15	120% of the rated torque	
4RK25	150% of the rated torque	
5RK40, 5RK60	160% of the rated torque	
5RK90	130% of the rated torque	

#### ● Installation conditions (For EN standard)

Overvoltage category II, Pollution degree 2, Class I equipment  
When the machinery to which the motor is mounted requires overvoltage category III specifications, install the motor in a cabinet that connect to power supply via an isolation transformer.

#### ■ Motor temperature rise tests

Temperature rise tests required by the above standards are performed in a state that has been attached a heat radiation plate instead of a gearhead.  
The size and material for the heat radiation plates are as follows.  
[Size] 2RK6: 115×115 mm (4.53×4.53 in.), 3RK15: 125×125 mm (4.92×4.92 in.), 4RK25: 135×135 mm (5.31×5.31 in.), 5RK40: 165×165 mm (6.50×6.50 in.), 5RK60, 5RK90: 200×200 mm (7.87×7.87 in.)  
[Thickness] 5 mm (0.20 in.)  
[Material] Aluminum alloy

#### ■ Standards for accessories

- Capacitor: UL File No.E83671 (CYWT2), VDE License Nos.112847 (capacitors with a rated voltage of 250 VAC), 114747 (capacitors with a rated voltage of 450 VAC)
- Capacitor cap: UL File No.E56078 (YDTU2)

- Unauthorized reproduction or copying of all or part of this manual is prohibited.
- Oriental Motor shall not be liable whatsoever for any problems relating to industrial property rights arising from use of any information, circuit, equipment or device provided or referenced in this manual.
- Characteristics, specifications and dimensions are subject to change without notice.
- While we make every effort to offer accurate information in the manual, we welcome your input. Should you find unclear descriptions, errors or omissions, please contact the nearest office.
- **Orientalmotor** is a registered trademark or trademark of Oriental Motor Co., Ltd., in Japan and other countries.

© Copyright ORIENTAL MOTOR CO., LTD. 2016

Published in November 2016

• Please contact your nearest Oriental Motor office for further information.

<b>ORIENTAL MOTOR U.S.A. CORP.</b> Technical Support Tel:(800)468-3982 8:30 A.M. to 5:00 P.M., P.S.T. (M-F) 7:30 A.M. to 5:00 P.M., C.S.T. (M-F) www.orientalmotor.com	<b>ORIENTAL MOTOR ASIA PACIFIC PTE. LTD.</b> Singapore Tel:1800-8420280 www.orientalmotor.com.sg
<b>ORIENTAL MOTOR DO BRASIL LTDA.</b> Tel:+55-11-3266-6018 www.orientalmotor.com.br	<b>ORIENTAL MOTOR (MALAYSIA) SDN. BHD.</b> Tel:1800-806161 www.orientalmotor.com.my
<b>ORIENTAL MOTOR (EUROPA) GmbH</b> Schiesstraße 74, 40549 Düsseldorf, Germany Technical Support Tel:00 800/22 55 66 22 www.orientalmotor.de	<b>ORIENTAL MOTOR (THAILAND) CO., LTD.</b> Tel:1800-888-981 www.orientalmotor.co.th
<b>ORIENTAL MOTOR (UK) LTD.</b> Tel:01256-347090 www.orientalmotor.co.uk	<b>ORIENTAL MOTOR (INDIA) PVT. LTD.</b> Tel:+91-80-41125586 www.orientalmotor.co.in
<b>ORIENTAL MOTOR (FRANCE) SARL</b> Tel:01 47 86 97 50 www.orientalmotor.fr	<b>TAIWAN ORIENTAL MOTOR CO., LTD.</b> Tel:0800-060708 www.orientalmotor.com.tw
<b>ORIENTAL MOTOR ITALIA s.r.l.</b> Tel:02-93906346 www.orientalmotor.it	<b>SHANGHAI ORIENTAL MOTOR CO., LTD.</b> Tel:400-820-6516 www.orientalmotor.com.cn
<b>ORIENTAL MOTOR CO., LTD.</b> 4-8-1 Higashiueno, Taito-ku, Tokyo 110-8536 Japan Tel:03-6744-0361 www.orientalmotor.co.jp	<b>INA ORIENTAL MOTOR CO., LTD.</b> Korea Tel:080-777-2042 www.inaom.co.kr <b>ORIENTAL MOTOR CO., LTD.</b> Hong Kong Branch Tel:+852-2427-9800

## Manufacturer's Literature – Siemens PLC

**SIEMENS**

6ED1052-1FB08-0BA1



LOGO! 230RCE logic module, display PS/I/O: 115V/230V/relay, 8 DI/4 DO, memory 400 blocks, modular expandable, Ethernet, integrated web server, data log, user-defined web pages, standard microSD card for LOGO! Soft Comfort V8.3 or higher, older projects executable cloud connection in all LOGO! 8.3 basic units

List Price	Show prices
Customer Price	Show prices
DataSheet in PDF	Download
Service & Support (Manuals, Certificates, FAQs...)	Download

Image similar

### Product

Article Number (Market Facing Number)	6ED1052-1FB08-0BA1
Product Description	LOGO! 230RCE logic module, display PS/I/O: 115V/230V/relay, 8 DI/4 DO, memory 400 blocks, modular expandable, Ethernet, integrated web server, data log, user-defined web pages, standard microSD card for LOGO! Soft Comfort V8.3 or higher, older projects executable cloud connection in all LOGO! 8.3 basic units
Product family	Ordering Data Overview
Product Lifecycle (PLM)	PM300 Active Product

### Price data

Region Specific PriceGroup / Headquarter Price Group	200 / 200
List Price	Show prices
Customer Price	Show prices
Surcharge for Raw Materials	None
Metal Factor	None

### Delivery information

Export Control Regulations	AL : N / ECCN : EAR99H
Standard lead time ex-works	25 Day/Days
Net Weight (kg)	0,274 Kg
Packaging Dimension	8,10 x 9,30 x 7,30
Package size unit of measure	CM
Quantity Unit	1 Piece
Packaging Quantity	1

### Additional Product Information

EAN	4034106033644
UPC	195125091542
Commodity Code	85371091
LKZ_FDB/ CatalogID	STLOGOI
Product Group	4071
Group Code	R131
Country of origin	China
Compliance with the substance restrictions according to RoHS directive	Since: 30.09.2020
Product class	A: Standard product which is a stock item could be returned within the returns guidelines/period.
WEEE (2012/19/EU) Take-Back Obligation	Yes
REACH Art. 33 Duty to inform according to the current list of candidates	

### Classifications

	Version	Classification
eClass	6	27-24-22-16
eClass	7.1	27-24-22-16
eClass	8	27-24-22-16
eClass	9	27-24-22-16
eClass	9.1	27-24-22-16
ETIM	5	EC001417
ETIM	6	EC001417
ETIM	7	EC001417
ETIM	8	EC001417
IDEA	4	3585
UNSPSC	15	32-15-17-05



Manufacturer's Literature – Anser U2 Printer



THERMAL INKJET PRINTERS  
OPERATION MANUAL

MODELS:

U2 SMART

U2 SMARTONE

U2 PRO-S

Copyright December 2018, Anser Coding Inc. All rights reserved.

This document is the property of Anser Coding Inc. and contains confidential and proprietary information owned by Anser. Any unauthorized copying, use or disclosure of it without the prior written permission of Anser is strictly prohibited.

---

**ANSER CODING INC**

---

34F, No.99, Sec.1, Xintai 5<sup>th</sup> Rd., Xizhi Dist.,  
New Taipei City 221, Taiwan  
[www.anser-u2.com](http://www.anser-u2.com)

Phone: +886 2 2697 3488  
Fax : +886 2 2697 3489

## Table of Contents

<b>1. ANSER Ink Jet Printer Components</b> .....	5
<b>1.1 Thermal Ink Jet (TIJ) Technology</b> .....	6
<b>1.2 ANSER TIJ inkjet printer portfolio</b> .....	6
<b>2. ANSER Ink Jet Printer Components</b> .....	7
<b>2.1 Printer Main Unit</b> .....	8
<b>2.2 Pocket-size Remote Keypad</b> .....	10
<b>2.3 Printer Assembly Kit</b> .....	12
<b>3. Installation</b> .....	13
<b>3.1 Printer Mounting Direction</b> .....	14
<b>3.2 Cartridge Insert &amp; Remove</b> .....	15
<b>3.3 Printer Startup &amp; Shutdown</b> .....	16
<b>3.3.1 Printer Startup</b> .....	16
<b>3.3.2 Printer Shutdown</b> .....	17
<b>4. User Interface Operation</b> .....	18
<b>4.1 Home Page</b> .....	19
<b>4.1.1 Status Bar</b> .....	20
<b>4.1.2 Print Preview</b> .....	22
<b>4.1.3 Real-Time Printing Report</b> .....	22
<b>4.2 Menu Settings Page</b> .....	23
<b>4.3 Editor</b> .....	23
<b>4.3.1 Message Selection and Printing</b> .....	24
<b>4.3.2 Adding New Message</b> .....	24
<b>4.3.3 Edit Message</b> .....	26
<b>4.3.4 Message Delay</b> .....	30
<b>4.3.5 Copy Message</b> .....	31
<b>4.3.6 Delete Message</b> .....	31
<b>4.3.7 Search Message</b> .....	31
<b>4.4 Editor Settings</b> .....	32
<b>4.4.1 Global Shift Table</b> .....	32
<b>4.4.2 Global String Table</b> .....	32
<b>4.4.3 Pre-Zero Format</b> .....	32
<b>4.4.4 Custom Year</b> .....	32
<b>4.5 System Settings</b> .....	33
<b>4.5.1 General Settings</b> .....	33
<b>4.5.2 Printhead Settings</b> .....	35
<b>4.5.3 Device Settings</b> .....	36
<b>4.5.4 Display Settings</b> .....	37
<b>4.5.5 Sound Settings</b> .....	37

4.5.6	Printer Status .....	37
4.6	Function Tree .....	38
5.	Additional Printer Operations.....	39
5.1	Printer Software Update .....	40
6.	MessagePRO II PC Software.....	41
6.1	USB Data Synchronization.....	42
6.2	Edit Message.....	42
6.3	Software Description.....	42
7.	Optional Accessories .....	43
7.1	External Photocell .....	44
7.2	External Encoder.....	44
7.3	Alarm Kit.....	45
7.4	Photocell and Encoder Installation.....	46
7.5	Sensors and Alarm Kit Installation.....	46
8.	Daily Protection and Maintenance .....	47
8.1	Cartridge Maintenance .....	48
8.2	Periodic Time Adjustment.....	48
8.3	Printer Maintenance .....	48
9.	Troubleshooting.....	49
9.1	Encoder Setting Problem.....	50
9.2	Photocell Setting Problem.....	50
10.	Specification .....	51
10.1	U2 Ink Jet Printer .....	52
10.2	External Photocell .....	53
10.3	External Encoder.....	54
10.4	Alarm Kit.....	55
10.5	Expansion Kit Box .....	56
11.	Installation / Operation Precautions .....	57
11.1	Installation Precautions .....	58
11.2	Operation Precautions .....	58

## 1. ANSER Ink Jet Printer Components

This section will cover brief introduction of:

**1.1 Thermal Ink Jet (TIJ) Technology**

**1.2 ANSER TIJ inkjet printer portfolio**



### 1.1 Thermal Ink Jet (TIJ) Technology

TIJ technology uses a drop ejection process, storing ink in a cartridge that regulates the pressure of the fluid. Inks are then delivered to the firing chamber to be heated at more than 1,000,000 C/second by an electric resistor. A 0.1 micrometer thick film of ink is heated to around 340C, from which a bubble is formed to expel the ink. A droplet breaks away from this bubble causing it to collapse, the firing chamber then refills as the whole process repeats.

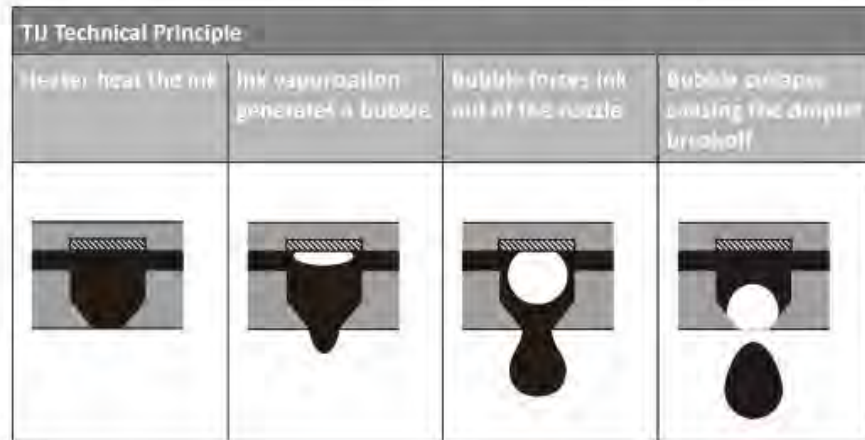

### 1.2 ANSER TIJ Inkjet printer portfolio

ANSER provide wide range of TIJ printing solution suitable for your ever-increasing coding demand....

	Substrate Type *		
	Porous	Semi Porous	Non-Porous
U2 Smart	c	c	
U2 SmartONE™	c	c	
U2 Diesel	c		
U2 Pro			c
U2 ProS	c	c	c
U2 MobileONE™	c	c	
* Substrate classification Porous: Paper, cardboard, sponge, untreated woods, etc. Semi Porous: Waxed surfaces, coated paper, plaster, concrete, etc. Non Porous: plastics, metals, varnished woods, glass, etc.			

## 2. ANSER Ink Jet Printer Components

This section covers detail explanation of ANSER printer components, which makes up from 3 major components include:

- 2.1 Printer Main Unit**
- 2.2 Pocket-sized Remote Keypad**
- 2.3 Assembly Kit**

**2.1 Printer Main Unit**

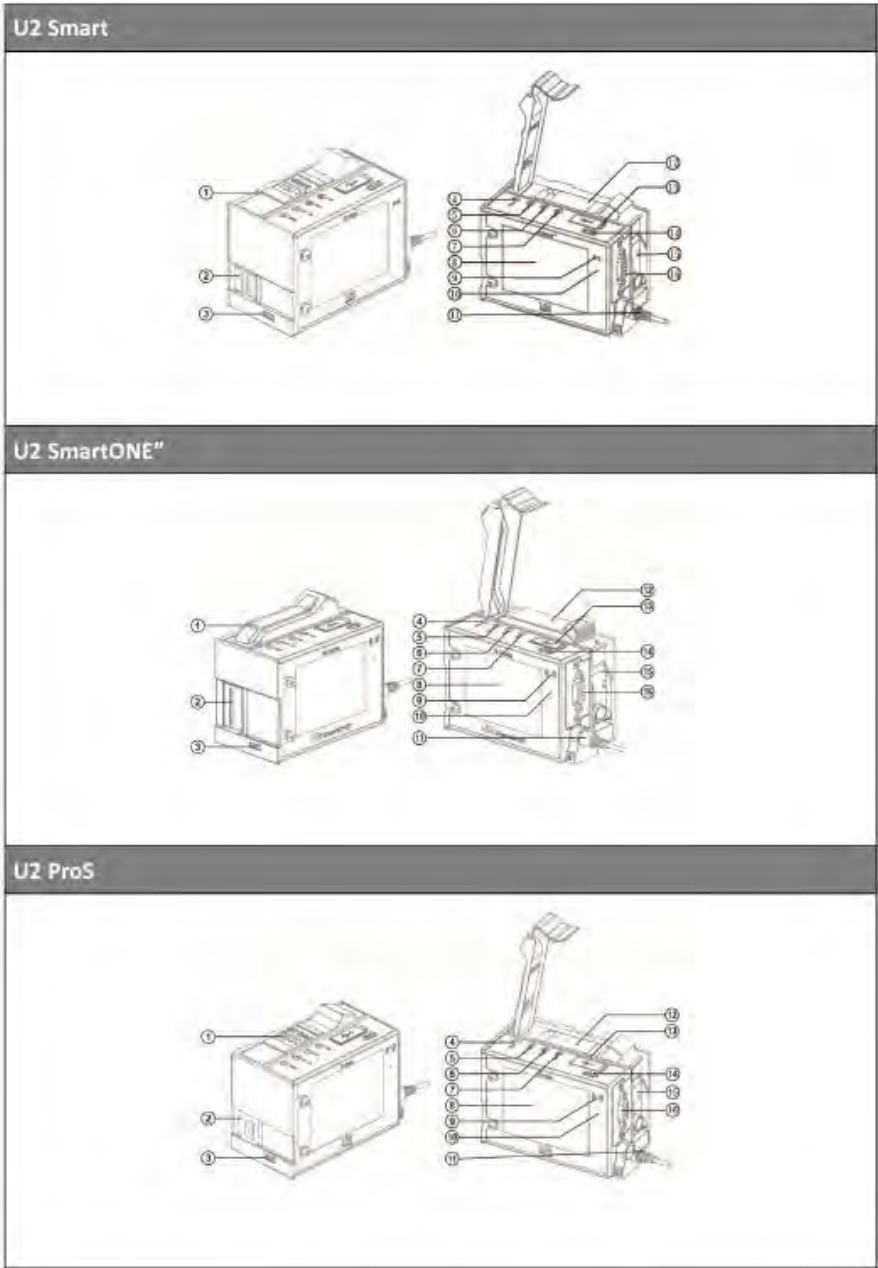

<b>1</b>	<b>Dust Cover</b>	Help to protect cartridge from getting damaged in harsh environment.
<b>2</b>	<b>Print Head</b>	The printhead uses the ink supplied by the ink bag to print the text and graphic characters on a product.
<b>3</b>	<b>Built-in Photocell</b>	Sensor that senses object and trigger printing function.
<b>4</b>	<b>Alarm LED</b>	LED will light up when cartridge has an error, no cartridge inserted, and no ink.
<b>5</b>	<b>Ink Low LED</b>	LED will light up when ink low.
<b>6</b>	<b>Print LED</b>	LED will light up during printing mode.
<b>7</b>	<b>Run LED</b>	LED will light up while power is connected
<b>8</b>	<b>Display Screen</b>	3.5-inch color LCD screen display options or printing content.
<b>9</b>	<b>Infrared Receiver</b>	Receives the infrared signal of the remote control.
<b>10</b>	<b>Infrared Receiver Light</b>	When it can receive signal indicator will light up.
<b>11</b>	<b>Power Port</b>	Connects AC adapter and power supply plug with its port.
<b>12</b>	<b>Ink Cartridge</b>	Ink cartridge containing ink.
<b>13</b>	<b>USB Port</b>	Port where USB can be connected
<b>14</b>	<b>Infrared On-Off Switch</b>	Infrared signal receiving switch button.
<b>15</b>	<b>Cartridge Latch</b>	Plug for fixed cartridge
<b>16</b>	<b>RS485 Port</b>	Port to connect alarm kit and external devices.

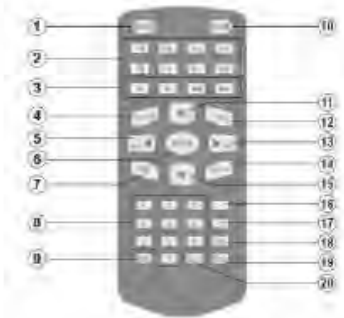

## 2.2 Pocket-size Remote Keypad

U2-Smart/U2-SmartONE"/U2-ProS can be operated by ANSER's remote keypad

U2 Printer Special Remote Control		
		
<b>1</b>	<b>Print On Key</b>	Start printing.
<b>2</b>	<b>Shortcut Editing Keys</b>	Existing Message content that contains; Time/Expire/Counter/Shift/Logo/Barcode and String. Operator can quickly access to the editing page to modify a specific content.
<b>3</b>	<b>Cursor Tab Keys</b>	These buttons allow you to move your cursor faster when creating new message.
<b>4</b>	<b>Function Settings key</b>	Shortcut to system settings page.
<b>5</b>	<b>Arrow Keys</b>	The arrow keys allow the operator to navigate through the software menus.
<b>6</b>	<b>Enter Key</b>	Confirm, save or apply a setting.

7	ESC Key	ESC key has multiple functions, and it allows operator to perform the following tasks; 1. Exit to main page 2. Go to previous page 3. Cancel a task
8	Alphanumeric Input Keys	To input alphabets and numbers when creating/editing a message.
9	Alphanumeric Switch Key	To switch between alphabets and numbers when creating/editing a message.
10	Print Off Key	Stop printing.
11	Arrow Keys	The arrow keys allow the operator to navigate through the software menus.
12	Tools Key	Shortcut to system status page.
13	Arrow Keys	The arrow keys allow the operator to navigate through the software menus.
14	Tab Key	Message delay quick access key.
15	Arrow Keys	The arrow keys allow the operator to navigate through the software menus.
16	Symbol Key	To select symbols when creating/editing a message.
17	BackSpace Key	Delete a single letter/number from the right.
18	Delete Key	No Function.
19	Enter Key	Functionality same as (6).
20	Space Key	To create a space to separate words.
* Battery Specification : CR2025		

**2.3 Printer Assembly Kit**

U2 Printer Assembly Kit		
1		3
2		
3		
1	<b>Anti-shock Clamp</b>	Absorbs and dissipates the vibration caused by the passing printing object.
2	<b>Clamps and Round Bars</b>	It allows you to install your printer in both horizontal and vertical print directions
3	<b>Base Clamp</b>	It secures the printer tightly to prevent movement or separation.

## 3. Installation

This section will cover brief introduction of:

- 3.1 Printer Mounting Direction**
- 3.2 Cartridge Insert & Remove**
- 3.3 Printer Startup & Shutdown**



## 3.1 Printer Mounting Direction

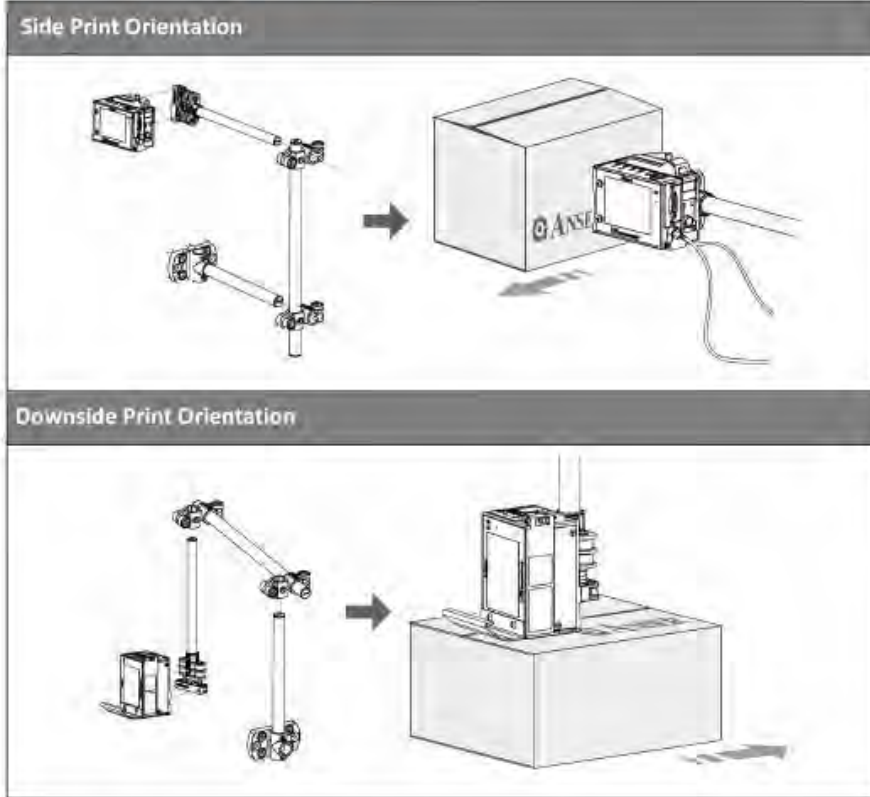

### ▲ Installation Consideration

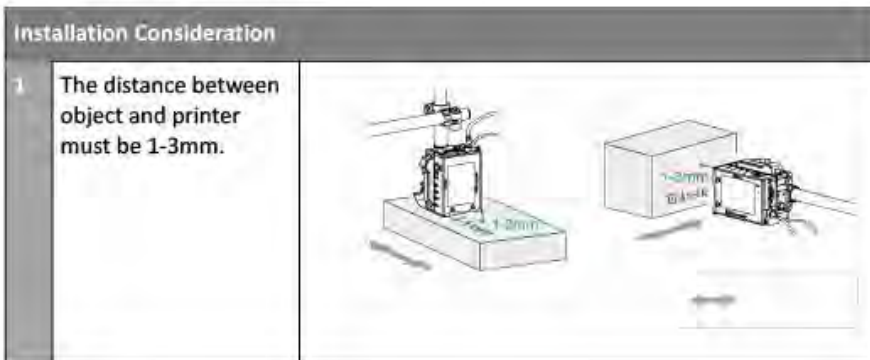

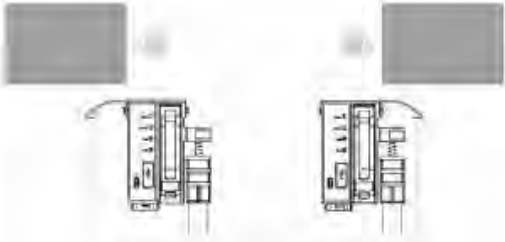
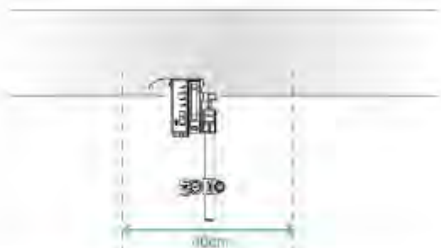
<p>2 Anti-shock plate should be installed according to the direction of the moving object.</p>	
<p>3 Keep a working area of at least 40 cm to facilitate on-site personnel to operate and maintain the equipment.</p>	

### 3.2 Cartridge Insert & Remove

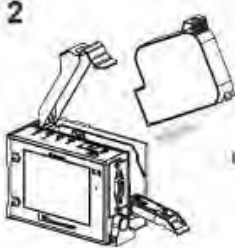
Inserting the Cartridge	
	
<p>1</p>	<p>1. Open the dust cover on the top of the printer. 2. Open the latch on the rear of the printer.</p>
<p>2</p>	<p>Insert the ink cartridge into the printer at a 15 degree angle and then press it down.</p>
<p>3</p>	<p>1. Close the latch on the rear of the printer. 2. Close the dust cover on the top of the printer.</p>

**Remove Ink Cartridge from Printer**

- \* Please make sure the printer is idle before removing ink cartridge from printer.
- \* Always cap your cartridge when it's not used. And, store the cartridge properly.

<b>1</b>	1. Open the dust cover on the top of the printer. 2. Open the latch on the rear of the printer.
<b>2</b>	Remove the ink cartridge from the printer at a 15 degree angle.
<b>3</b>	1. Close the latch on the rear of the printer. 2. Close the dust cover on the top of the printer.

### 3.3 Printer Startup & Shutdown

#### 3.3.1 Printer Startup

**CAUTION:** Only use the power adapter provided by ANSER.

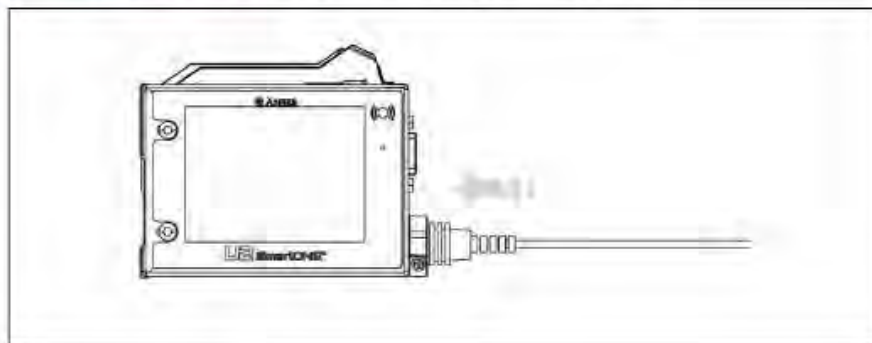

Plug the power adapter into the 12VDC socket and plug the power adapter into a wall outlet, or the power source.

**3.3.2** Printer Shutdown

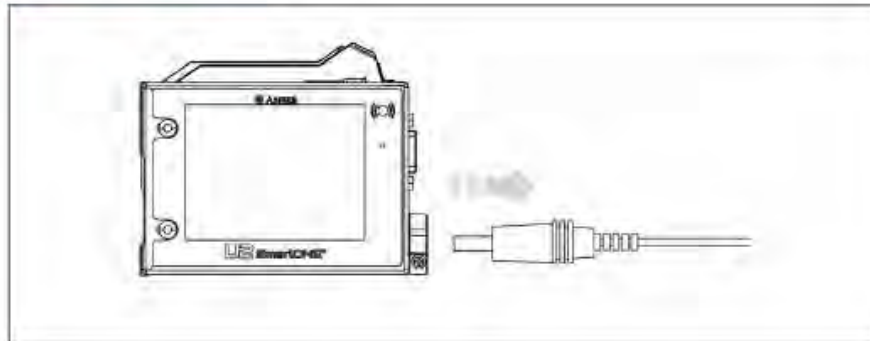

**CAUTION:** Please make sure printer is idle before unplugging the power adapter, to prevent damage to the printer and ink cartridge.

## 4. User Interface Operation

This section covers detail explanation of ANSER printer user interface:

- 4.1 Home Page
- 4.2 Menu Settings Page
- 4.3 Editor
- 4.4 Editor Settings
- 4.5 System Settings
- 4.6 Function Tree

Before start operation in U2 printer, please make sure infrared receiver is turn on (bright IR LED light). If no, please press the infrared switch button to turn it on.



## 4.1 Home Page

U2 Printer main page is divided into three sections: system status, print preview and real-time printing report. The functions are as follow:



**U2 ProS System Main Page**



The screenshot shows the U2 ProS System Main Page. At the top, there is a status bar with icons for power, USB, external hardware, UV, and system time (00:00:00, 08/08/2018). Below this is a 'Print Preview' section containing a QR code, a barcode, and the text 'MFD:08/08/2018 EXP:08/08/2020 CODING JUST GOT EASY'. At the bottom is a 'Real-time Printing Report' section showing 'Product Counter: 888' and 'Dateline: 08/08/2018'. Three numbered callouts (1, 2, 3) point to the status bar, print preview, and report sections respectively.

1	System Status	Display current hardware device status, print status, external hardware and device memory time, etc.
2	Print Preview	Preview real-time printing message.
3	Real-time Printing Report	Instantly display print related information, such as counters, number of prints, etc.

#### 4.1.1 Status Bar

Provides the user's current device status, including print status, USB status, external photocell status, external encoder status, ink status and system time, for each function diagram see the table below for instructions.

**U2 Smart / SmartONE® Status Bar**







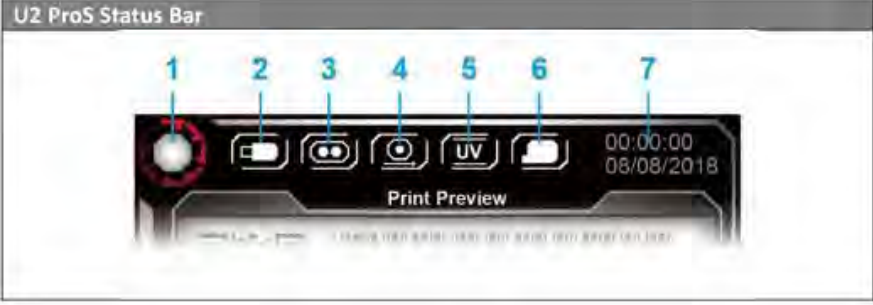



















The screenshot shows the U2 Smart / SmartONE Status Bar. It features seven numbered callouts (1-7) pointing to various status indicators: 1 (power), 2 (USB), 3 (external photocell), 4 (external encoder), 6 (ink status), and 7 (system time). The system time displayed is 2017/06/20 13:19:30. Below the indicators is a 'Print Preview' section.

**U2 ProS Status Bar**



The screenshot shows the U2 ProS Status Bar. It features seven numbered callouts (1-7) pointing to various status indicators: 1 (power), 2 (USB), 3 (external photocell), 4 (external encoder), 5 (UV), 6 (ink status), and 7 (system time). The system time displayed is 00:00:00, 08/08/2018. Below the indicators is a 'Print Preview' section.

	Status Name	U2 Smart / SmartONE™	U2 ProS	Description
1	Printing Status			It shows whether the current printer is performing printing task. During printing, the icon rotates otherwise remains still.
2	USB Status			USB port is connected to a storage device in the original format.
				USB port is connected to USB WIFI dongle.
				USB port is connected to USB Ethernet dongle.
				USB port is connected to USB keyboard
				No USB connected or detected.
3	External Photocell			External photocell enabled, this function needs manual setup.
				External photocell not enabled.
4	Encoder Status			Encoder enabled, this function needs manual setup.
				Encoder not enabled.
6	Cartridge Status			Cartridge already inserted.
				Ink cartridge detection abnormal or does not exist.
7	System Time	Display printer current system time.		



#### 4.1.2 Print Preview

Present the printing content that the printer is about to/is printing.

**Print Preview**



Display the message that the printer is about to print, and when the message length exceeds the screen display area, the remote control  can be used in the system main screen.

#### 4.1.3 Real-Time Printing Report.

Presents current device related printing information, such as ink consumption, counter status, printing serial number content, etc.

**Real-time Printing Report**



1	<b>Product Counter</b>	Count the number of prints done since the first print.
2	<b>Counter, Box, Lot</b>	When message content contains counter information, display the printing content.
3	<b>Surplus</b>	Display ink cartridge residual ink volume and estimated number of prints.
	<b>Datetime</b>	When message content contains date time related information, display the printing content.

### 4.2 Menu Settings Page

In U2 printers home page,  can be used to call out the menu settings page, and use the left and right direction keys and enter key to select.







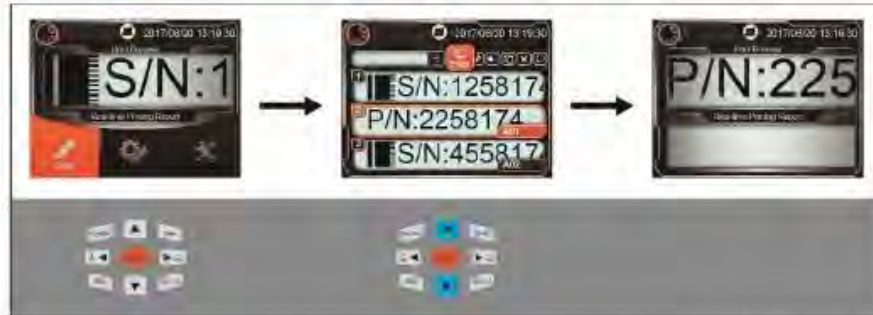

### 4.3 Editor

From U2 printer main menu select "Editor" to enter message list interface. User can use the operation bar to add, delete, edit, etc., printer memory information. The detailed functions are as follow:







### 4.3.1 Message Selection and Printing



In the message list   select and print the message  , after selecting, system will automatically return to main screen and start printing. After selecting the message, you can also use remote control keys  ,  to perform print start/stop operation.



### 4.3.2 Adding New Message

In the message list screen can use remote control  ,  select  to enter add new message page. The page contains 3 blocks: Message preview, message name and message objects. When adding a new message you can edit the message name first and then select message object by pressing  and enter to edit the message object.



Before adding a new message, user needs to first set the message mode to free mode or line mode (support 1-4 lines). The free mode will not limit the height and placement of the message object. The line mode will fix the height of each message object to maximum height and line them up equally, and the position is aligned with the upper edge of each line. After setting completed, will enter to the new message object page. Message editing mode is introduced in the next chapter.



Free Mode



Line Mode

### 4.3.3 Edit Message

U2 Printer constructs the message that the user needs to print in an object-based manner. Edit message page have 5 actions can be performed: Add, edit, move, delete and edit message name.

#### Add Message Object



User commonly used printing content is integrated into eight “message objects” for user editing: Text, production date, expiry date, counter, shift, logo, barcode and string. Each object is described below:

#### a. Text

Text such as product name, description text and any text can be received as fixed text content in every print. The font of text object can be Arial or gothic, and the parameter settings include: font size and angle (0°, 90°, 180°, 270°).

#### b. Time / Expire

The current time information stored internally can be used to create manufacture date or expiry date according to the set validity period. This feature allows users to edit 30 type of time formats including: year, month, day, time, minute, second, Jewish day, number of weeks, week, AM/PM and custom symbols.

**c. Counter**

U2 printer internally have 3 types of counters: General counter, box counter and lot counter. Every counter has four parameters that can set: Maximum value, minimum value, start value (current value) and increment value. When the counter reaches maximum value, it will automatically return to minimum value, where the box counter also causes the lot counter to carry.

**d. Shift**

The work shift table divides the day into several time periods, and each time slot has a shift name. For example, if the current time is 09:14, the content corresponding to shift would be AAA, then the object will be printed as AAA. The system support setting 24 groups as limit.



**e. Logo**

Select the image object, the source of image can be imported from Message Pro using USB and then imported into the system. The supported format is bmp black and white image file. The image size supports up to 150 pixels height and 26200 pixels long.

**f. Barcode**

U2 printer supports editing static text in barcodes, such as CODE-128 barcode content as text. If you need to print dynamic barcode content, you can use the Message Pro II to generate. The supported barcodes as listed in below table:

	Name 1	Name 2	Description
1	EAN8		
2	EAN13		
3	DUN14		
4	EAN128		
5	UPCA		
6	UPCE		
7	CODE39		
8	CODE128		
9	ITF14	SCC-14	
10	NVE18	SSCC18	
11	C25INTER		INTER25
12	CODABAR		
13	PDF417		
14	DATAMATRIX		
15	QRCODE		
16	GS1 DataBar		
17	GS1 DATAMATRIX		

**g. String**





U2 printer system enables users to set their own strings, such as: company name, URL, etc., for users to quickly edit messages. The system supports up to 5 string groups.

## Edit Message Object



## Move Message Object



After each message object is edited, it will enter the message preview screen, and remote control keys     can be used to adjust the position of the object.





**Edit Message Name**



**4.3.4 Message Delay**

The setting of printing delay of a single message. U2 Printer system has built-in three type of printing delays: Repeat printing delay, global delay and message delay. When the three settings are in conflict with each other, the system determines the priority as "Repeat printing delay">" Global delay">" Message delay". The difference between these three delays is described below:



**Repeat printing delay :** From "System Settings" → "Printhead "can perform setup. Setting values contain "Initial print delay" and "Continuous print delay".

**Global delay :** From "System Settings" → "General "can perform setup.

**Message delay :** From "Edit" → "delay "can perform setup.

#### 4.3.5 Copy Message

Makes a copy of system internal message. The message number can be the minimum empty value selected automatically by system or be customized by the user.

#### 4.3.6 Delete Message

Delete system internal message. After deletion, the message code will be left blank and not automatically filled.

#### 4.3.7 Search Message

Reduce the time of message search by searching for user-defined messages in the system by message name.



#### 4.4 Editor Settings

The "Editor Settings" main menu can be used for "Global shift table", "Global string table", "Pre-zero format" and "Custom year" to improve the efficiency of message editing. Functions are described below:

##### 4.4.1 Global Shift Table

Shift objects within a message can be edit by going through "Main menu" → "Global Shift Table" to the editing page.

##### 4.4.2 Global String Table

String objects within a message can be edit by going through "Main menu" → "Global String Table" to the editing page.

##### 4.4.3 Pre-Zero Format

When setting system printing dynamic values, the rendering of meaningless characters before numerical values, there are three items can be set: Time, date and counter as show in the following table:

	Time ( Actual Time am 01:08:06 )	Date ( Actual date 2018/01/05 )	Counter ( 0~999 · present value 8 )
Fill 0	01:08:06	2018/01/05	008
Align Left	1-:8-:6-	2018/1-/5-	8--
Align Right	-1-:8-:6	2018/-1-/5	-8
Compact	1:8:6	2018/1/5	8

##### 4.4.4 Custom Year

Custom year have two features, one to set custom year and one to set roll over date time.

**Custom Year:** If this value is set as 107, the printing year will be change to 0107.

**Rollover Hour:** User-defined rollover date time setting, for example: Rollover time set as 23:50, current date time as 2018/01/05 23:52, then the system will automatically go forward one day printing 2018/01/06 23:52.

## 4.3 System Settings

When U2 printer software system is running, while on main menu or message page can press  to enter system settings page. There are 6 items in the system settings: General settings, printhead settings, device settings, display settings, sound settings, and printer status.

### 4.3.1 General Settings

General settings are for **setting** the basic values of the system, setting items are as follow

#### Language

U2 Printer supports 20 different languages: Traditional Chinese, Simplified Chinese, Japanese, Korean, English, German, Portuguese, Spanish, Russian, French, Italian, Turkish, Hungarian, Slovak, Czech, Switzerland, Romanian, Polish, Serbian, Bulgarian.

#### Measurement Units

Select British imperial (Inch) or Metric system (millimeter)

#### Password Setup

When the password function is turned on, every time printer is power on will prompt to enter password so as to record usage. The system allows up to 5 sets of user password to be set. System default Administrator password: 1234, Please manage and keep it safe.

#### Font

U2 printer system has built-in two types of fonts Arial and Gothic. System also provides custom fonts for usage. User can use USB to import custom fonts and select from the "custom fonts" menu.

### Global Delay

The print delay applies to all messages in the printer. When the global delay has been set, printer will ignore message delay value and use the global delay value as the main parameter. See 4.3.4



### Daylight Saving

Set daylight saving function:

Daylight Format	Start	End
Europe	Every year on the last Sunday of March, at 01:59:59, it jumps to 03:00:00.	The last Sunday of October each year 01:59:59 in the morning, jump to 01:00:00
USA	Every year on the second Sunday of March, at 01:59:59, it jumps to 03:00:00.	The first Sunday of November each year 01:59:59 in the morning, jump to 01:00:00

### System Time

Adjust current system time: (Year/month/day H:M:S)

### Log Report

Function	Description
Clear Log	Clear the content of the log file.
Backup Log	Before backing up, please make sure the USB is plugged into printer. Back up the log file to USB://auprn/u2d/report.log Back up the log file to USB://auprn/u2s/report.log
Export / Import Settings	Before using, please make sure the USB is plugged into printer. Export settings to USB file or Import from USB into system
Export / Import Message	Before using, please make sure USB has been inserted Export all messages to USB file or import from USB into system.

## Restore Default

It will reset all setting values to factory default, but user-defined message will be completely retained.

### 4.5.2 Printhead Settings

Printhead settings sets the values of cartridge printhead, setting items are described below:

#### Direction

 : Printing from left to right,

 : Printing from right to left,

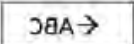
 : Rotation 180° from left to right,

 : Rotation 180° from right to left.

#### Horizontal Resolution

##### Encoder Off

System support range: 50~600 DPI (50 DPI per step) .

##### Encoder On

- 300 DPI encoder system support : 150 DPI, 300DPI.
- 400 DPI encoder system support: 200 DPI, 400DPI.

#### Pre-Purge

System pre-purge is a pre-spray for the equipment's standby state to keep the nozzle moist. Humidity can be set (1~5), the more dryer the environment (or the more volatile the ink), the greater the setting value should be.

#### Repeat Printing

The printer **continuously** prints the same message according to the setting content, setting content as below:

Options \ Content		Setting Content	
<b>Trigger</b>	Off	On	On
<b>Option</b>	-	Infinite Printing	Finite Printing
<b>Count</b>	-	-	0-65535
<b>Initial Delay</b>	-	0-5548mm	0-5548mm
<b>Gap</b>	10-5548mm	10-5548mm	10-5548mm
<b>Use</b>	Auto repeat printing	Photocell trigger, infinite number of prints	Photocell trigger, finite number of prints

#### Real Time Refresh

Print **time** related information, the frequency of the update time. Can set instant refresh (follow system time) or set time interval update (setting range: 1~9 minutes).

#### Clean Nozzles

Used **when** ink is stuck or clogged at the nozzles.

### 4.5.3 Device Settings

Devices settings include the settings of photocell, encoder, WIFI and Ethernet settings items are as follow:

**Photocell Source:** it can be external or internal, system default is internal. After photocell is installed, user must manually set external option.

**Photocell Mode:** trigger photocell mode can be positive or negative edge trigger.

**Encoder:** after encoder is installed, user must manually set external option and user should choose printhead resolution same as the encoder when using external encoder.

**Conveyor Speed:** input current conveyor speed, this function is only available when **encoder** is off.

**Box Width:** set target width (Unit: mm)

**Wireless Network:** set the settings related to WIFI connection. This feature is only enabled when USB to WIFI dongle is connected.

**Ethernet:** set the settings related to Ethernet connection. This feature is only enabled when USB to Ethernet dongle is connected.

#### 4.5.4 Display Settings

Set the brightness of the LCD screen, time value of screensaver, and LCD test.

**Screen Brightness:** set screen brightness, range 1~10.

**Screen saver:** screen saver time, range 1~60 minutes.

**LCD Test:** after enabled, LCD will display R(red), G(green), B(blue), W(white) each one second.

#### 4.5.5 Sound Settings

Set counter alarm, keypad tone and printing beep. User can also detect buzzer through check sound option.

#### 4.5.6 Printer Status

The current software and hardware version, distributor code, ink, cartridge and system alarms related **information** can be queried in the status function.

**Printer:** display printer S/N, software and hardware version information.

**Ink:** display ink volume.

**Cartridge:** display cartridge type and printing information.

**Alarm:** display system errors.



### 4.6 Function Tree

Printer's system has three main functions: "Edit", "Editor Settings" and "System Settings". System function tree is as follow:

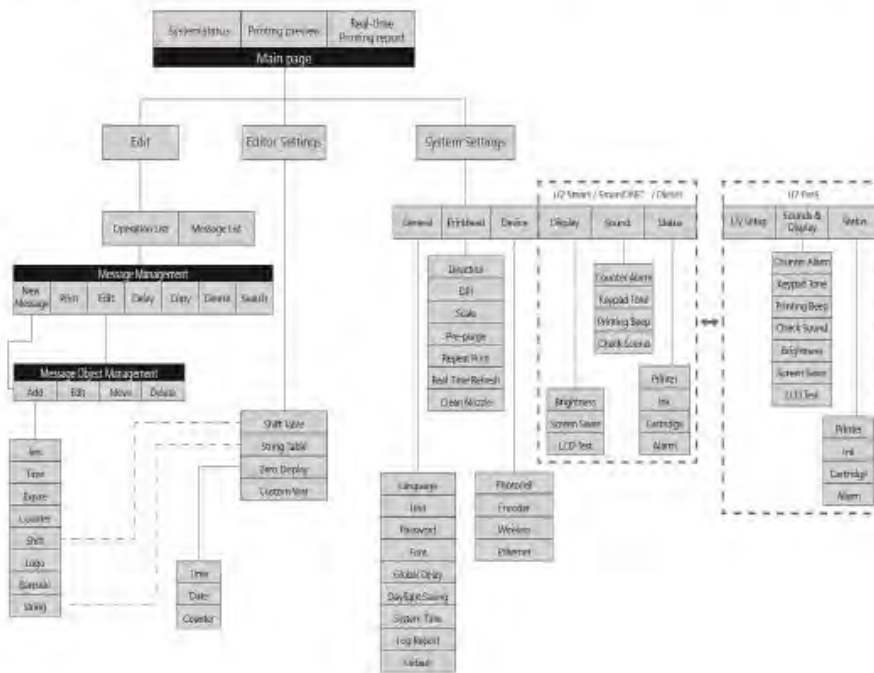

## 5. Additional Printer Operations

This section covers additional operations:

### 5.1 Printer Software Update

### 5.1 Printer Software Update

#### Updating By USB

1. Copy the .ans file into firmware folder on the auprn→firmware USB directory.
2. Stay at the main page of printer interface and insert the USB.
3. Follow the on-screen instructions.
4. Please wait 90 seconds then disconnect and reconnect the power cable.

*Note: If the instruction does not appear automatically after 10 seconds, re-insert the USB.*

## 6. MessagePRO II PC Software

This section covers operation of PC software:

**6.1 USB Data Synchronization**

**6.2 Edit Message**

**6.3 Software Description**

MessagePRO II is a proprietary software which can be paired with U2 2<sup>nd</sup> series printers. It provides complete and powerful editing functions and USB can be used to exchange messages and software updates.

### 6.1 USB Data Synchronization

Please use the supplied U2 exclusive USB. If you need to use your own USB flash drive, first time using USB, while on printer's main page insert USB to perform format.

### 6.2 Edit Message

1. Insert the formatted USB into PC.
2. From MessagePro II, open and edit messages in the USB directory.
3. After finish editing, insert the USB back into the printer.
4. Printer will ask "Import and overwrite from USB", press "Yes" to import all message into printer.

#### Notice

1. When messages are synchronized, fonts and images are automatically imported into the system.
2. When messages are synchronized, all internal messages in the printer will be overwrite.
3. When messages are synchronized, time and date format, shift table, string table, custom year, zero display formats (time/date/counter) in the configuration file will also be imported into the system.

### 6.3 Software Description

For detailed instructions on MessagePro II, please refer to MessagePro II user manual.

## 7. Optional Accessories

This section covers information related to external accessories that can be connected to U2 printers:

- 7.1 External Photocell**
- 7.2 External Encoder**
- 7.3 Alarm Kit**
- 7.4 Photocell and Encoder Installation**
- 7.5 Sensors and Alarm Kit Installation**

U2 printers can support external photocell, encoder and warning light, their specifications and installation method are described below:

## **7.1 External Photocell**

Provide more reliable and precise sensing parameter

If internal photocell cannot be used because of printing position, please connect external photocell.

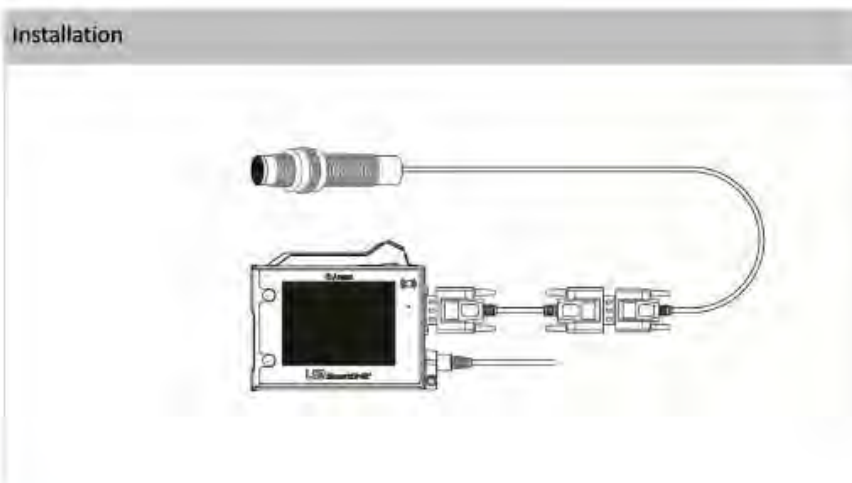

## **7.2 External Encoder**

Provide high print quality on unstable conveyor

Encoder detects the line speed so that printer can print correctly. Need to be set in a place where can detect the same speed as the movement of the product.

Installation

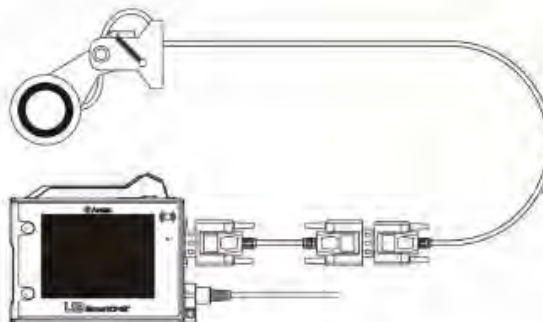

**7.3 Alarm Kit**

Alert users in the event of an incident, warning light needs to be pair up with the Smart I/O expansion kit to be used.

Installation





## 7.4 Photocell and Encoder Installation

When both photocell and encoder need to be installed together please use Y-cable, as shown in the following figure:

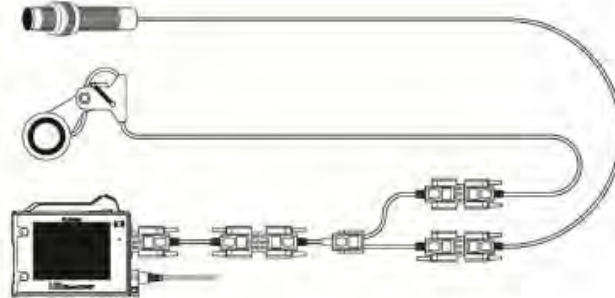

## 7.5 Sensors and Alarm Kit Installation

When need to install warning light, photocell and encoder all at the same time, please use the expansion kit. The installation is shown in the following figure:



## 8. Daily Protection and Maintenance

This section covers important information regarding the daily maintenance of both printer and cartridges:

- 8.1 Cartridge Maintenance**
- 8.2 Periodic Time Adjustment**
- 8.3 Printer Maintenance**

For normal use, the following daily maintenance operations are required:

### 8.1 Cartridge Maintenance

To ensure print quality, the following maintenance is required:

#### **Uptime Maintenance**

During uptime, put the special wet towel on the wiping board, gently wipe the cartridge nozzles part, gently wipe the ink cartridge with a width of about 10 cm.

#### **Downtime Maintenance**

1. Downtime less than 1 hour does not require special maintenance. However, the printed product may be subject to deviation due to the use environment. If there is any deviation in the printed product, please put the special wet tissue on the wiping board, gently wipe the nozzle part of the ink cartridge, and gently wipe the ink cartridge with a width of about 10 cm.
2. Downtime more than 1 hour, please stop printing mode and then perform uptime maintenance.

#### **Long Downtime**

When downtime more than 2 days, remove ink cartridge from the printer and cover the printhead with the protective clip and placed in a special collection box for proper collection.

### 8.2 Periodic Time Adjustment

To avoid system time variation, it is recommended that the user periodically correct the system clock. In particular, when you need to print date or time of production and expiration date. Please be sure to adjust the system time once a week.

### 8.3 Printer Maintenance

Cleaning of printer may become necessary when working on dusty environments that could cause accumulation of debris on both printer and cartridge.

Please use isopropyl alcohol dampened lint-free moist cloth and gently clean the pen board electrical pins and DISC module pins.

## 9. Troubleshooting

This section covers topics related to the functioning of the printer:

**9.1 Encoder Setting Problem**

**9.2 Photocell Setting Problem**

The following is the recommended troubleshooting procedure when the user encounters a fault on the printing. When abnormal printing occurs in the printer, you can follow the steps below to perform simple troubleshooting. If the user cannot solve the problem according to procedure, please contact distributor or the manufacturer for technical support.

### 9.1 Encoder



### 9.2 Photocell

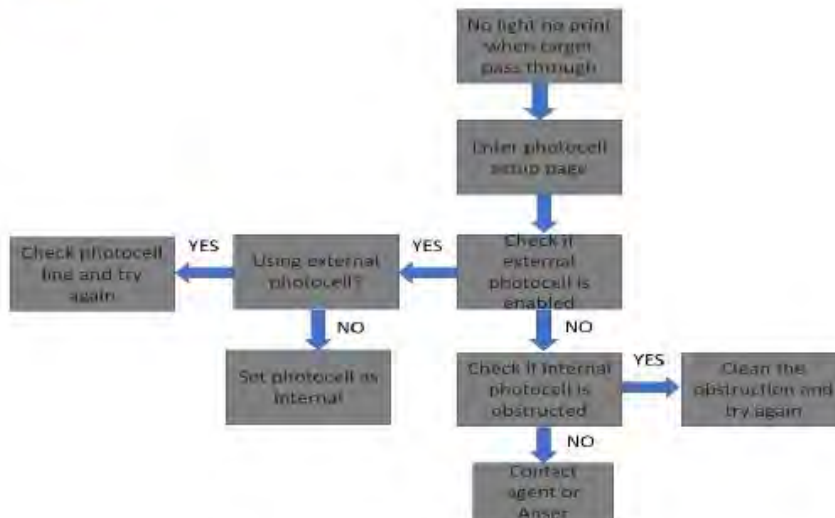

## 10. Specification

This section covers information related to the technical specifications of printer and external accessories:

- 10.1 U2 Inkjet Printer**
- 10.2 External Photocell**
- 10.3 External Encoder**
- 10.4 Alarm Kit**
- 10.5 Expansion Kit Box**

**10.1 U2 Ink Jet Printer**

<b>Printer</b>	
Display	3.5" color screen, display screen 320x240 pixels and backlight display
User Interface	Offline operation (no computer connection required) Group network printing via personal/tablet computer
Input Device	Pocket-sized IR remote keypad
Available Languages	English, Japanese, French, German, Spanish, Portuguese, Russian, Korean, Italian, Turkish, Hungarian, Slovak, Czech, Swedish, Romanian, Polish, Serbian, Bulgarian, Chinese (Traditional & Simplified)
LED Indicators	Alarm, ink Low, Print, Run, Remote on/off
Dimensions	119 x 78.8 x 76 mm
Weight	550g
Printing Orientation	Horizontal or downside
Operating Temperature	5°C-40°C (41°F-104°F)
Data Interface	RS-485, USB HOST
<b>Power Specifications</b>	
External power supply	AC input 100V~240V, 50/60Hz
	DC output 12V, 5A ; total 60 W
<b>Optional Accessories</b>	
External Encoder	High quality printing is ensured when the conveyor speed is unstable
External Photocell	Provide external photocell to increase installation convenience
External Warning Light	The indicator light can be connected externally to facilitate timely detection of faults.

## 10.2 External Photocell

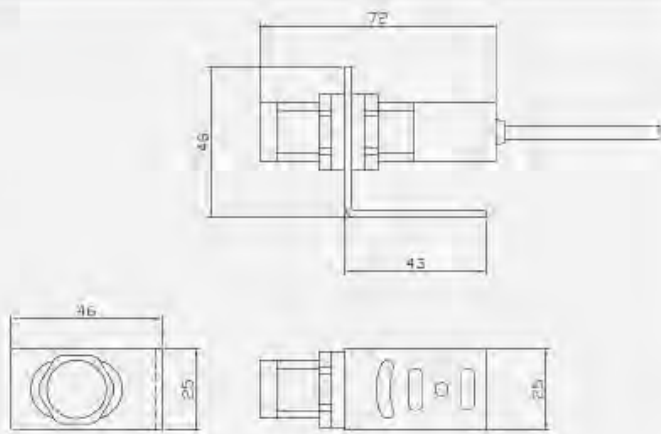
Specification	
	
<b>Dimensions</b>	D×H : $\Phi 22.0 \times 72.0$ ( mm )
<b>Cable Length</b>	1.9m + 0.24m ( 9-pin 15-pin conversion cable )
<b>Sensing Distance</b>	300mm below
Content Items	
Photocell	1
9-pin 15-pin conversion cable	1
Screw to adjust sensitivity	1
Line mounting bracket	1
Bracket for controller installation	1
Screw	2
Washer	2
Nut	2

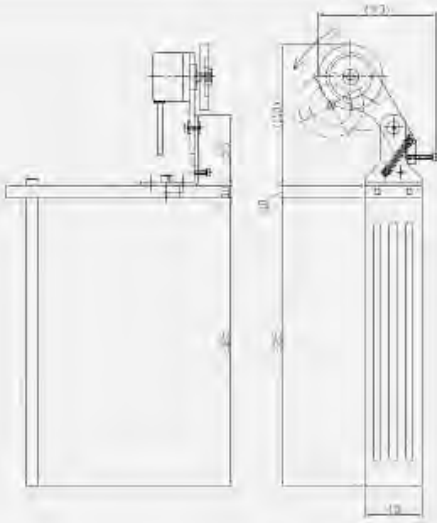

### 10.3 External Encoder

Specification	
	
<b>Wheel Diameter</b>	49.7mm
<b>Resolution</b>	300 or 400 DPI
<b>Cable Length</b>	1.9m + 0.24m ( 9-pin 15-pin conversion cable )
Content Items	
<b>Encoder</b>	1
<b>9-pin 15-pin conversion cable</b>	1
<b>Encoder mounting bracket (main)</b>	1
<b>Encoder mounting bracket (horizontal)</b>	1
<b>M6×L20 screw</b>	8
<b>M6 washer</b>	8
<b>M6 Nut</b>	8

10.4 Alarm Kit

**Warning Lamp body**

<b>Dimensions</b>	D×H : Φ80.0×316.0 ( mm )
<b>Weight</b>	600g
<b>Signal Pattern</b>	Red light, yellow light, green light, warning beep
<b>Cable Length</b>	3.0m

**10.5 Expansion Kit Box**

**Expansion Kit Box**

<b>Red Light</b>	No ink, no cartridge, unknown cartridge
<b>Yellow Light</b>	Low ink
<b>Green Light</b>	Printing Mode (can print)
<b>Alarm Beep</b>	No ink

**Output Input Terminals**

## 11. Installation / Operation Precautions

This section covers information related to precautions that should be consider during installation and operation of printer:

### 11.1 Installation Precautions

### 11.2 Operation Precautions

### 11.1 Installation Precautions

1. The printer must be equipped with an anti-collision mechanism and tighten all screws after installation. In the absence of an anti-collision mechanism for the nozzle, any external damage suffered (such as a box impact nozzle) is not covered by the warranty.
2. Please remove the cartridge at a 15-degree angle.
3. Users are strongly advised to ground the power supply, and should avoid sharing power with large power equipment such as motors.
4. If there is too much dust in the working environment, it is strongly recommended to use an air compressor to remove internal dust.

### 11.2 Operation Precautions

1. When the printing result is blurred, please confirm that the distance between the nozzle and the object remain within 5mm for the best print distance.
2. When ink trailing occurs in the print, please wipe the surface of cartridge nozzle with the special wipe.
3. If the printing position is not correct, please press the [Tab | →] button on the remote control to set the optimal printing position.
4. By default no action after 30 seconds will activate the screen protection mechanism. The screen will automatically turn off, press any key in the remote control to restart the screen.
5. If the printer appears cannot solve the fault, please contact the distributor.